



BR 20a · PTFE-lined Ball valve DIN- and ANSI-Version



Application

Tight-closing PTFE-lined ball valve for corrosive media, especially for high process demand in chemical plants:

- **Nominal size DN 15 to 200 and NPS $\frac{1}{2}$ to 8**
- **Nominal pressure PN 16 and cl150**
- **Temperatures -10 °C to 200 °C (14 °F to 392 °F)** (others on request)

The controlling device consists of a PTFE-lined ball valve with a pneumatic quarter-turn actuator, a manual gear or a lever.

The valves are designed according to the modular-assembly principle have the following features:

- Full bore, high KV values
- Body of EN-JS 1049 (0.7043 / A395) for nominal sizes from DN 25 / NPS1 or 1.0460 / A105 for nominal sizes up to DN 20 / NPS $\frac{3}{4}$ with PTFE lining (min. 5 mm wall thickness)
- Exchangeable PTFE seat rings
- 1 pcs ball/stem of stainless steel (1.4313) with PTFE liner (min. 5 mm wall thickness)
- Hysteresis-free, perfect for control applications
- Shaft sealed by a self-adjusting PTFE V-ring packing, supported by disc springs, maintenance-free
- On/off operation with leakage rate A acc. to DIN EN 12266-1, bubble-tight version
- Blowout-proof shaft
- Connecting flange for actuators acc. to DIN ISO 521 1
- DIN version with face-to-face dimensions acc. to DIN EN 558
- ANSI version with face-to-face dimensions acc. to ASME B16.10
- High-quality 2-component PU coating (RAL 1019) as protection against corrosive atmosphere and corrosive formation

Versions

Ball valve are optionally available in the following versions:

- Ball valve with lever (DN 15 to 100 or NPS $\frac{1}{2}$ to 4)
- Ball valve with manual gear
- Ball valve with pneumatic quarter-turn actuator (see associated data sheet for details)
- Acc. to customer specifications



Fig. 1: PTFE-lined BR 20a Ball valve

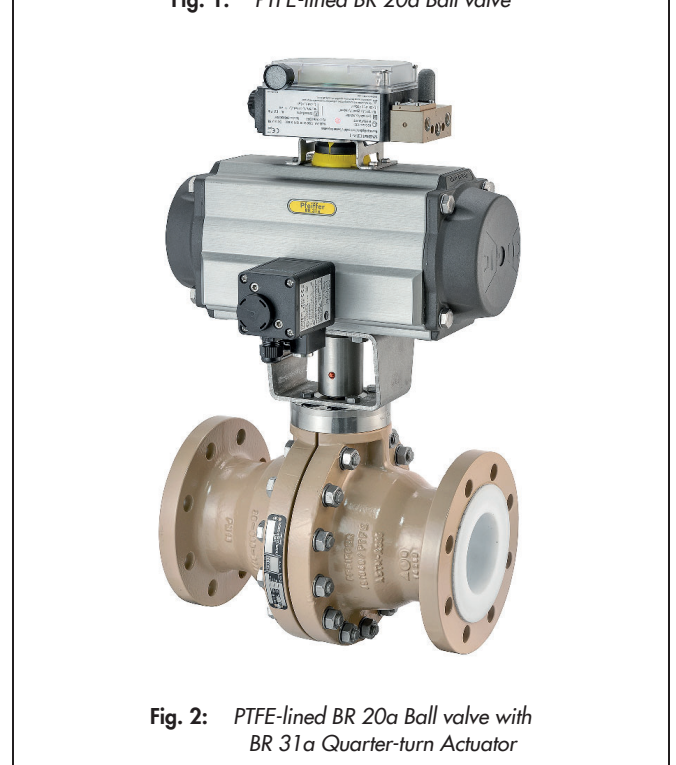

Fig. 2: PTFE-lined BR 20a Ball valve with BR 31a Quarter-turn Actuator

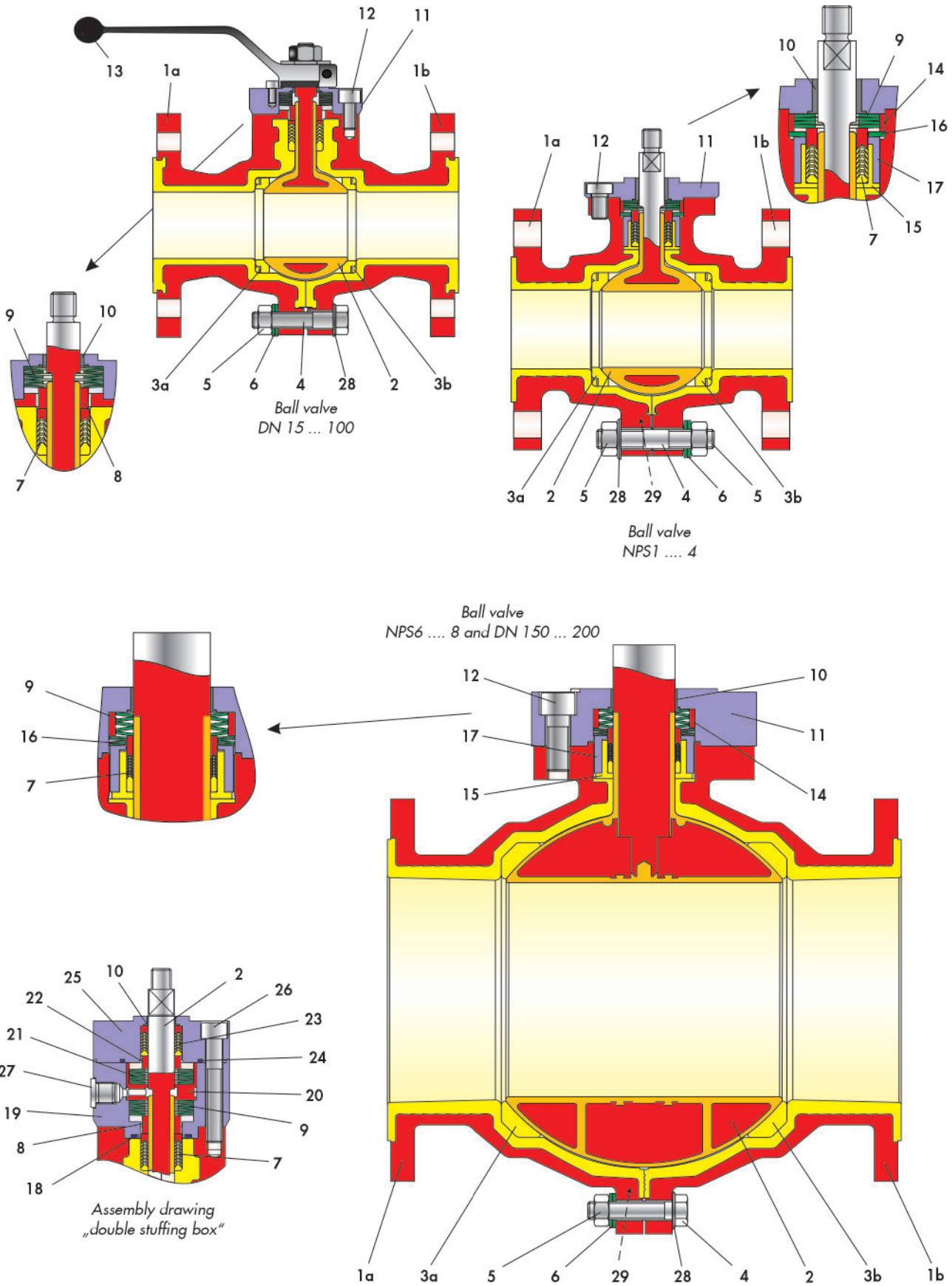

Fig. 3: Sectional drawing of the BR 20a Ball valve

Table 1: Parts list

Pos.	Designation	Pos.	Designation	Pos.	Designation
1	Body with lining	11	Stuffing box flange	21	Set of spring washers
2	Ball with coating	12	Screw	22	Thrust ring
3	Seat ring	13	Hand lever	23	V-ring packing
4	Screw/ stud bolt	14	Center ring	24	O-ring
5	Nut	15	PTFE bush	25	Stuffing box upper section
6	Spring washer	16	Spring washer	26	Screw
7	V-ring packing	17	Bush	27	Screw plug
8	Thrust ring	18	O-ring	28	Washer
9	Set of spring washers	19	Stuffing box lower section	29	Pin
10	Bearing bush	20	Distance bush		

¹⁾ Depending on the nominal width, stud bolts can be fitted with nuts or screws.

Special versions

- Valve body made of stainless steel 1.4571
- Lined bottom drain ball valve, see Series 21a
- Ball valve for controlling by characteristic seat ring
- Liner with special PTFE compounds
- Lining PTFE - conductive
- Heating jacket, stainless steel
- Stem sealing with two PTFE V-ring packings and test connection
- Flange groove acc. to DIN EN 1092
- Several materials for ball and sealing rings
- FDA conform sealing materials
- Acc. to customer specifications

Principle of operation

The BR 20a Ball valves allow the full flow through the valve in either direction.

The ball (2) with its cylindrical passage slew around the middle axis.

The opening angle of the ball determines the flow through between the body (1) and bore.

When the ball valve is opened, the entire profile is available.

The ball (2) is sealed by exchangeable seat rings (3).

The ball shaft is sealed by a PTFE V-ring packing (7) which is spring supported by disc springs (9) positioned above the packing.

The shaft is equipped with a lever (13). Optionally, a pneumatic actuator or gear-operated actuator can be assembled.

Fail-safe position

Depending on assembly position of the pneumatic actuator, the valve has two fail-safe positions which become effective when the air pressure in the actuator is relieved or when the supply air fails:

- **Ball valve with fail-close actuator**

While air failure, the valve is closed.

The valve opens when the signal pressure increases, acting against the force of the springs.

- **Ball valve with fail-open actuator**

While air failure, the valve opens.

The valve closes when the signal pressure increases, acting against the force of the springs.

i Note

BR 20a Ball valves can also be used for control applications. Refer to the data sheet ► DB 20a-kd.

i Note

Before using the valve in hazardous areas, check whether this is possible according to ATEX 2014/34/EU by referring to the mounting and operating instructions ► EB 20a.

Optional material combinations

For best adaption to process conditions, it is possible to optimize ball valve by modification of materials (eg. body, shaft, ball and sealing).

Additional accessories

The following accessories are available (separately or in combination):

- Locking device
 - Shaft extension (100 mm, standard)
 - Pneumatic or electric quarter-turn actuators
 - Positioner
 - Limit switches
 - Solenoid valves
 - Filter regulator
 - Heating jacket available for various nominal sizes on request (not for ANSI versions)
 - Ball valve for control application by characteristic seat ring
- Further accessories are possible on customer request.

Advantages of the live-loaded sealing system

- Maintenance-free and self-adjusting
- Highest tightness, even under extreme pressure and temperature conditions
- High durability

All in all: Extremely economic!

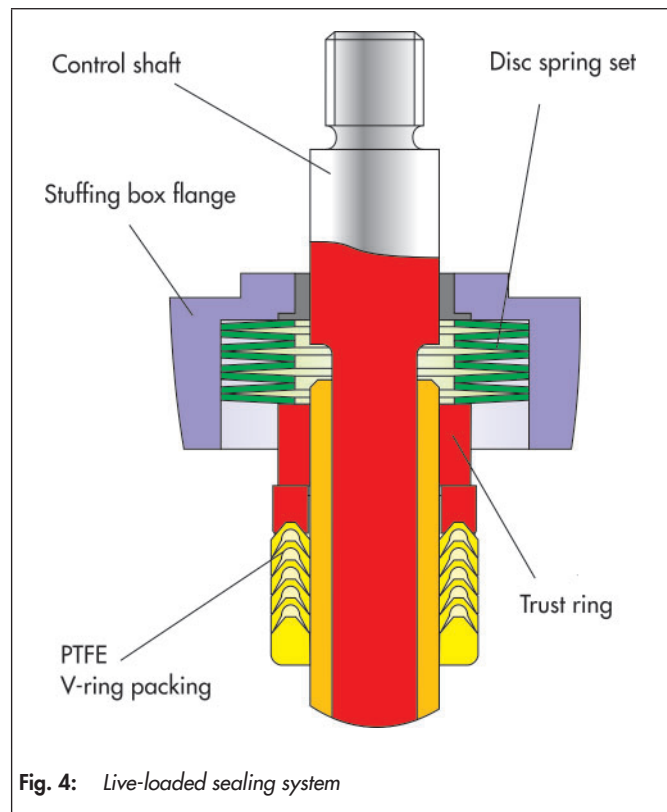

Fig. 4: Live-loaded sealing system

Table 2: General technical data

	DIN	ANSI
Nominal size	DN 15 ... 200	NPS½ ... 8
Nominal pressure	PN 16	cl150
Temperature range	-10 °C ... 200 °C (14 °F ... 392 °F)	
Ball sealing	PTFE	
Leakage rate	Leakage rate A acc. to DIN EN 12266-1, P12	
Flanges	DIN EN 1092-2, Form B	ASME B16.5
Packing	PTFE V-ring packing supported by disc springs	
Face to face dimensions	DIN EN 558 row 1, DN 15 ... 150 DIN EN 558 row 12, DN 200	ASME B16.10 Short Pattern A, NPS½ ... 6 (without NPS¾) ASME B16.10 Short Pattern B, NPS¾ and NPS8

Table 3: Materials

		DIN	ANSI
Body	DN15 ... DN20 NPS½ ... NPS¾	1.0460 with PTFE lining (min. 5 mm)	A105 with PTFE lining (min. 5 mm)
	DN25 / NPS1 and larger	EN-JS 1049 / 0.7043 with PTFE lining (min. 5 mm)	A395 with PTFE lining (min. 5 mm)
Ball / Shaft		1.4313 / 1.4317 with PTFE-casing (min. 5mm)	
Seat rings		PTFE	
Packing		PTFE - V-ring-packing	
Disc spring set		1.8159, Delta Tone	
Bearing bush		PTFE with 25% carbon	
Body sealing		PTFE	
Coating		2-Components Pur-Varnish colour grey beige, (RAL 1019)	

Pressure-temperature diagrams

The operating range is given by the pressure-temperature diagram. Process data and medium may influence the values in the diagram.

Pressure-temperature diagram, PN 16

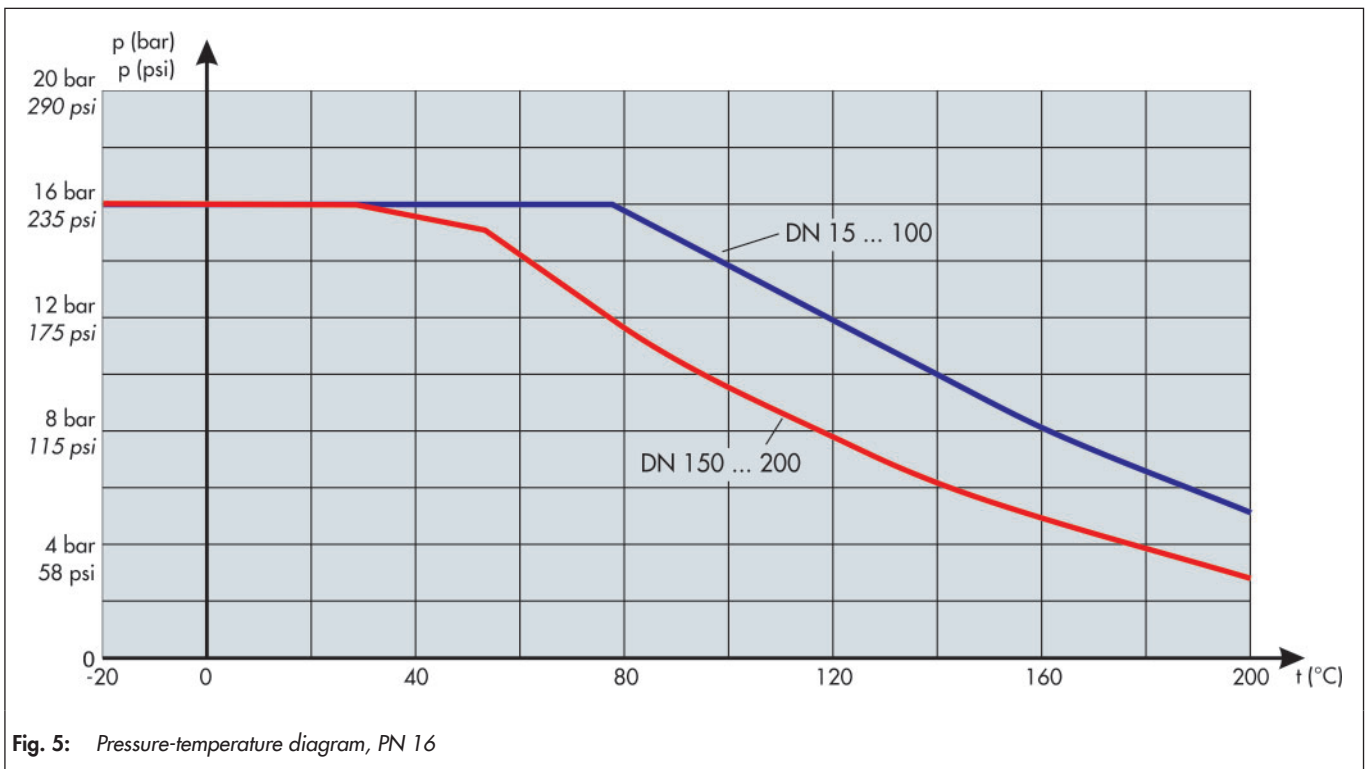

Pressure-temperature diagram, Class 150

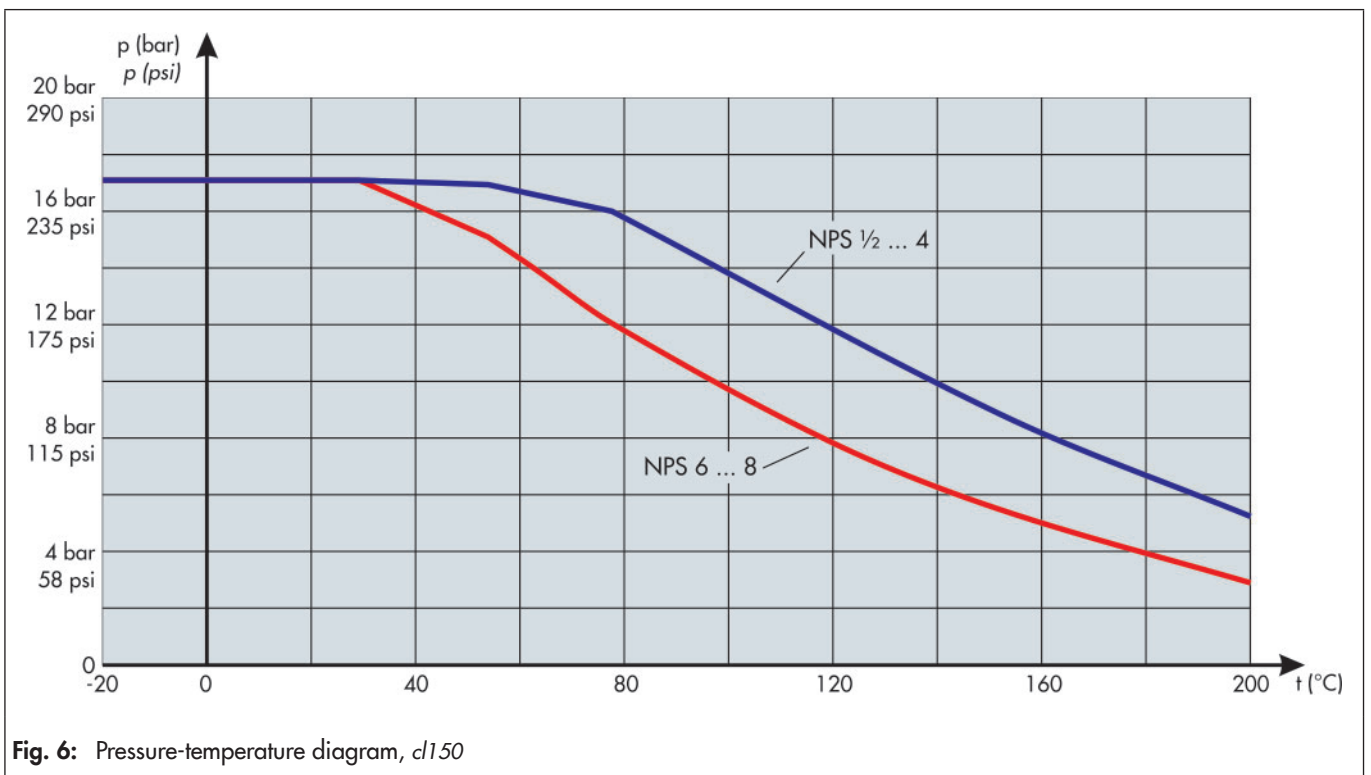

Table 4: *kvs* and *Cv* coefficients

DN	15	20	25	40	50	80	100	150	200
NPS	½	¾	1	1 ½	2	3	4	6	8
<i>kvs</i>	10	10	45	105	163	402	587	1554	2670
<i>Cv</i>	12	12	52	122	190	467	682	1810	3111

Table 5: *Torques and breakaway torques*

DN	NPS	Differential pressure Δp in bar		0	5	10	16
		perm. operating torque MDmax. in Nm	required operating torque Md in Nm				
15	½	126	6	10	10	10	12
20	¾	126	6	10	11	12	15
25	1	140	5	7.5	10	14	17
40	1 ½	140	10	15	15	18	22
50	2	140	15	22.5	23	28	34
80	3	608	38	57	62	80	90
100	4	833	60	90	110	130	140
150	6	1570	210	300	380	450	540
200	8	6515	270	380	430	505	570

The above listed torques are based on the opening of the ball valve at the differential pressure for water with corrosion inhibitors added at room temperature and with one-day non-actuation. Since temperature, pressure, process medium, switching frequencies and idle times considerably affect the arising torques, corresponding factors need to be taken into consideration on selecting and sizing the actuator. In case of doubt, contact Pfeiffer. The listed maximum permissible torques apply to the standard material listed in Table 3.

Dimensions and weights

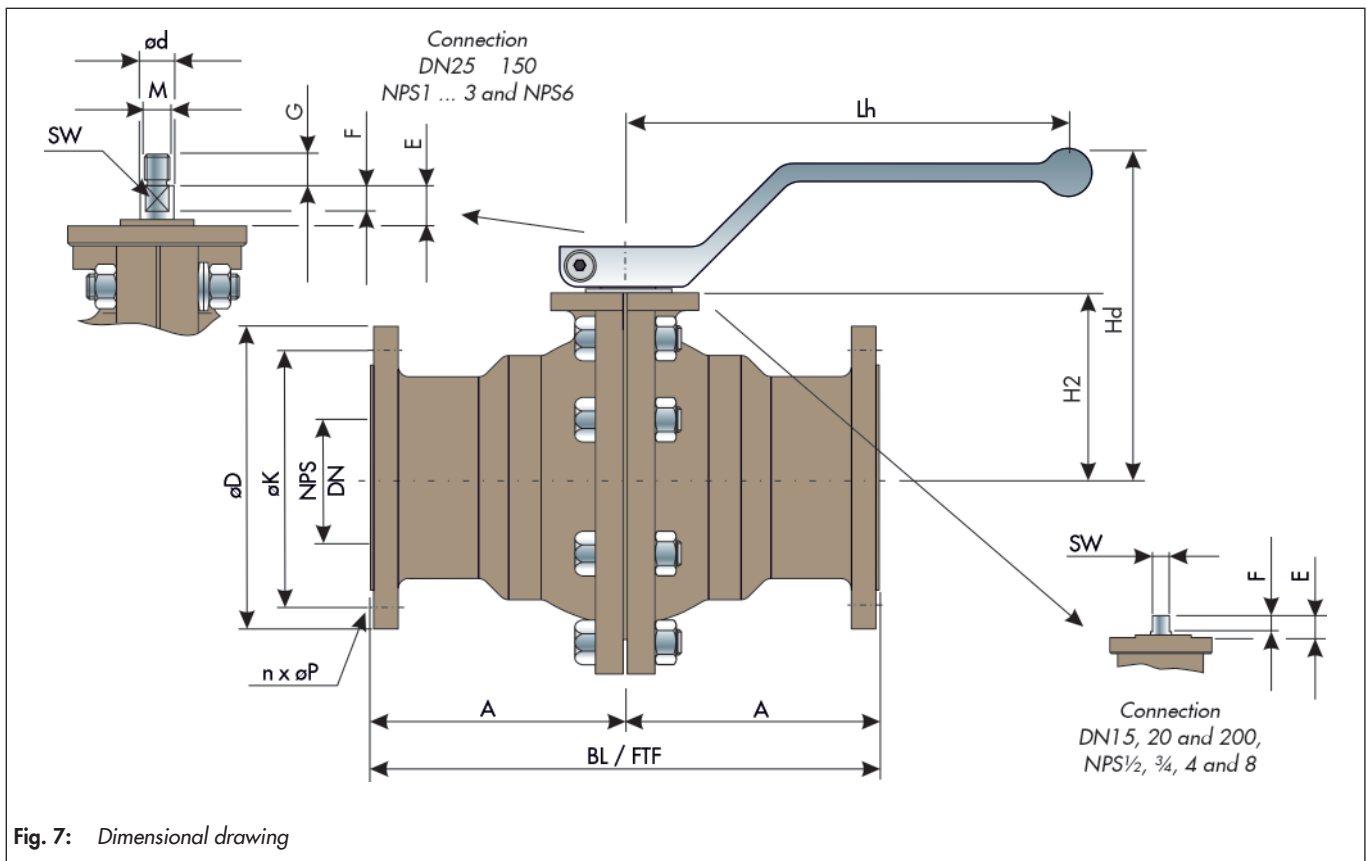

Table 6: Dimensions in mm and weights in kg for the DIN version

DN	15	20	25	40	50	80	100	150	200
BL / FTF	130	150	160	200	230	310	350	480	457
A	65	75	80	100	115	155	175	240	228.5
H2	50	61.2	82	96	103	138.5	161	210.5	265
Hd	122	122	150	159	164	195.5	213	-	-
Ød	16.8	16.8	16.8	16.8	16.8	24	28	46	55
ØD	95	105	115	150	152	199	219	285	340
E	19	19	19	19	19	23	19	29	42
F	12	12	12	12	12	12	12	18	34
G	-	-	15	15	15	18	18	17	-
M	-	-	M12	M12	M12	M16	M16	M24	-
Lh	220	220	220	183.5	183.5	365	365	-	-
SW	12	12	12	12	12	16	20	24	34
DIN ISO Anschluss	F05	F05	F05	F05	F05	F07	F07	F14	F16
ØK	65	75	85	110	125	160	180	240	295
nxØP	4x14	4x14	4x14	4x18	4x18	8x18	8x18	8x22	8x22
Gewicht	5	6	6	12.4	14	26	37	85	156

Table 7: Dimensions in mm and weights in kg for the ANSI version

NPS	½	¾	1	1½	2	3	4	6	8
BL / FTF	108	150	127	165	178	203	229	267	419
A	54	75	63.5	82.5	89	101.5	114.5	133.5	209.5
H2	48	61.2	82	96	103	138.5	153	210	265
Hd	124	124	152	172	179	185.5	213	-	-
Ød	16.8	16.8	16.8	16.8	16.8	24	28	46	55
ØD	90	100	108	127	152.4	190.5	228.6	279.4	343
E	19	19	19	19	19	23	19	29	42
F	12	12	12	12	12	12	12	18	34
G	-	-	15	15	15	18	-	17	-
M	-	-	M12	M12	M12	M16	-	M24	-
Lh	220	220	220	220	220	365	365	-	-
SW	12	12	12	12	12	16	20	24	34
DIN ISO Anschluss	F05	F05	F05	F05	F05	F07	F07	F14	F16
ØK	60.3	69.9	79.2	98.6	120.7	152.4	190.5	241	298
nxØP	4x15.7	4x15.7	4x15.7	4x15.7	4x19.1	4x19.1	8x19.1	8x22.2	8x22.2
Gewicht	4.5	5	5.5	9.5	11	18	29	85	120

Selection and sizing of the drain ball valve

1. Determine the required nominal size
2. Select valve in accordance with table 2 resp. 3 and by pressure-Temperature diagram
3. Select the appropriate actuator using table 5
4. Select additional equipment

Order text

BR 20a PTFE-lined ball valve

Nominal size: DN / NPS

Nominal pressure: PN / cl

Optional special version

Lever, resp. actuator (brand name):

Supply pressure: bar

Fail-safe position:

Limit switch (brand name):

Solenoid valve (brand name):

Positioner (brand name):

Other:

i Note

All relevant details regarding the version ordered, which deviate from the specified version in this technical description data, can be taken if required, from the corresponding order confirm

Associated documents

- Mounting and operating instructions ▶ EB 20a
- Safety manual ▶ SH 20
- Pneumatic Multi-turn actuator ▶ TB 30a
- Pneumatic Quarter-turn actuator ▶ TB 31a