



## SH 3962-9 EN

Translation of original instructions



## Type 3962-9 Solenoid Valve

## Definition of signal words

### **DANGER**

*Hazardous situations which, if not avoided, will result in death or serious injury*

### **WARNING**

*Hazardous situations which, if not avoided, could result in death or serious injury*

### **NOTICE**

*Property damage message or malfunction*

### **Note**

*Additional information*

### **Tip**

*Recommended action*

## Purpose of this manual

The Safety Manual SH 3962-9 contains information relevant for the use of the Type 3962-9 Solenoid Valve in safety-instrumented systems according to IEC 61508 and IEC 61511. The safety manual is intended for planners, constructors and operators of safety-instrumented systems.

---

### **!** NOTICE

#### **Risk of malfunction due to incorrect mounting, connection or start-up of the device.**

- Refer to the Mounting and Operating Instructions EB 3962-9 on how to mount the device, perform the electric and pneumatic connections as well as start up the device.
  - Observe the warnings and safety instructions written in the Mounting and Operating Instructions EB 3962-9.
- 

## Further documentation

The documents listed below contain descriptions of the start-up, functioning and operation of the solenoid valve. You can download these documents from the SAMSON website.

- ▶ T 3962: Data sheet
  - ▶ EB 3962-9: Mounting and operating instructions
- 

### **i** Note

*In addition to the solenoid valve documentation, observe the documentation for the pneumatic actuator, valve and other valve accessories.*

---

## Contents

<b>1</b>	<b>Scope .....</b>	<b>5</b>
1.1	General .....	5
1.2	Use in safety-instrumented systems .....	5
1.3	Versions and ordering data .....	5
1.4	Types of attachment.....	8
<b>2</b>	<b>Technical data .....</b>	<b>9</b>
<b>3</b>	<b>Safety-related functions .....</b>	<b>13</b>
3.1	Fail-safe action .....	13
<b>4</b>	<b>Mounting, connection and start-up.....</b>	<b>13</b>
<b>5</b>	<b>Required conditions .....</b>	<b>15</b>
5.1	Selection .....	15
5.2	Mechanical and pneumatic installation .....	15
5.3	Electrical installation.....	16
<b>6</b>	<b>Proof testing.....</b>	<b>17</b>
6.1	Function testing.....	17
6.2	Visual inspection to avoid systematic failure .....	18
<b>7</b>	<b>Repairs .....</b>	<b>19</b>
<b>8</b>	<b>Safety-related data and certificates .....</b>	<b>19</b>

# 1 Scope

## 1.1 General

The Type 3962-9 Solenoid Valve consists of a pilot valve and a booster valve. It converts binary voltage signals into pneumatic control signals. It is used to control pneumatic rotary and linear actuators with spring-return mechanism.

## 1.2 Use in safety-instrumented systems

Observing the requirements of IEC 61508, the systematic capability of the solenoid valve for emergency venting as a component in safety-instrumented systems is given.

Use of the solenoid valve is possible on observing the requirements of IEC 61511 and the required hardware fault tolerance in safety-instrumented systems up to SIL 2 (single device/HFT = 0).

The individual safety functions of the solenoid valve are to be regarded as Type A elements in accordance with IEC 61508-2.

---

**i Note**

*The architecture and the interval between proof tests must be changed accordingly for a higher safety integrity level.*

---

## 1.3 Versions and ordering data

All versions of the solenoid valve marked with the prefix **SIL** are suitable for use in safety-instrumented systems. The article code written on the nameplate (see next pages) provides details on the optional equipment of the solenoid valve.

Article code

Solenoid valve	Type 3962-	x	x	x	x	x	x	x	x	x	x	x	x	x	x	x	x	x	x	x
Explosion protection																				
Ex d	SIL 9																			
Nominal signal																				
24 V DC	SIL 3 0																			
230 V AC/DC	SIL 4 0																			
115 V AC/DC	SIL 7 0																			
48 V AC	SIL 9 1																			
Type of protection																				
II 2 G D																				
ATEX Ex db IIC T3/T4/T5/T6 Gb																				
Ex tb IIC T85°C/T100°C/T135°C/T200°C Db																				
SIL 2 1 0																				
IECEX Ex d IIC T*/DIP A21 T* (on request)																				
SIL 2 1 1																				
NEPSI Ex d IIC T3-T6 Gb/DIP A21 (on request)																				
SIL 2 1 2																				
EAC 1Ex d IIC T6/T5/T4/T3 Gb X																				
1Ex d IIC T5 Gb X																				
SIL 2 1 3																				
STCC II 2G Ex d IIC Ta*																				
II 2D Ex tD A21 T* IP66																				
SIL 2 1 6																				
Manual override																				
Without	SIL	0																		
External pushbutton			2																	
External toggle switch			4																	
Switching function																				
3/2-way function with spring-return mechanism	SIL	0																		
5/2-way function with spring-return mechanism <sup>1)</sup>			1																	
5/2-way function with two detent positions			2																	
5/3-way function with spring-centered mid-position (ports 2 and 4 closed)			3																	
5/3-way function with spring-centered mid-position (ports 2 and 4 supplied with air)			4																	
5/3-way function with spring-centered mid-position (ports 2 and 4 vented)			5																	
6/2-way function with spring-return mechanism			6																	

Solenoid valve		Type 3962-	x	x	x	x	x	x	x	x	x	x	x	x	x	x	x	x	x	x
Attachment																				
NAMUR interface according to VDI/VDE 3845	SIL	0																		
Threaded connection for wall or pipe mounting	SIL	1																		
CNOMO interface, 30 mm (pilot valve as spare part)	SIL	2																		
K <sub>VS</sub> <sup>1)</sup>																				
1.4 <sup>3)</sup>		3																		
4.3	SIL	4																		
0.05 (pilot valve as spare part)	SIL	5																		
2.9 <sup>4)</sup>		6																		
2.0	SIL	7																		
Enclosure material																				
Aluminum	SIL	0																		
Stainless steel	SIL	1																		
Pneumatic connection																				
G ¼	SIL	0																		
¼ NPT	SIL	1																		
G ½	SIL	2																		
½ NPT	SIL	3																		
Without threaded connections (pilot valve as spare part)	SIL	4																		
Supply																				
Internal pilot supply for actuators for on/off service	SIL	0																		
External pilot supply for actuators for throttling service	SIL	1																		
Electrical connection																				
Cable entry M20x1.5 (female)	SIL	0	0																	
Cable gland M20x1.5, black polyamide	SIL	0	1																	
Adapter M20x1.5 (male) to ½ NPT (female)	SIL	1	2																	
Connector according to EN 175301-803, type A, black polyamide <sup>5)</sup>	SIL	2	3																	
Degree of protection																				
IP 66	SIL		2																	
Ambient temperature <sup>6)</sup>																				
-20 to +40 °C (max. +80 °C in T4)	SIL																			2
-45 to +40 °C (max. +80 °C in T4)	SIL																			3

## Scope

Solenoid valve	Type 3962-	x	x	x	x	x	x	x	x	x	x	x	x	x	x	x	x	x	x	
Safety approval																				
Without																		0		
SIL																		1		
Special version																				
Without																		0	0	0

1) Not with NAMUR interface,  $K_{VS}$  4.3

2) The air flow rate when  $p_1 = 2.4$  bar and  $p_2 = 1.0$  bar is calculated using the following formula:

$$Q = K_{VS} \times 36.22 \text{ in m}^3/\text{h}.$$

3) A distance plate is required with NAMUR interface/type of protection Ex d (► EB 3962-9).

4) On request

5) The cable socket is not included in the scope of delivery. The degree of protection is only guaranteed when the cable socket and gasket underneath it are mounted.

6) The permissible ambient temperature of the solenoid valve depends on the permissible ambient temperature of the components, type of protection and temperature class.

## 1.4 Types of attachment

The solenoid valve is suitable for the following types of attachment in combination with various mounting parts:

- Attachment to rotary actuators with NAMUR interface according to VDI/VDE 3845
- Attachment to linear actuators with NAMUR rib according to IEC 60534-6-1
- Pipe mounting



## 2 Technical data

General data for pilot valve		
Type	3962-9	
Design	Solenoid and poppet valve with return spring	
Degree of protection	IP 66	
Material	Enclosure	Stainless steel, epoxy powder coated, red (spool housing) aluminum, hard anodized, black (CNOMO connection block)
	Internal parts	Stainless steel and brass
	Screws	Stainless steel
	Seals	FKM
Mounting orientation	Any desired position	
Approx. weight	850 g	

Electrical data for pilot valve with type of protection flameproof enclosure Ex d					
Type		3962-930	3962-940	3962-960/-970	3962-980
Nominal signal	$U_N$	24 V DC ( $\pm 10\%$ )	230 V AC/DC ( $\pm 10\%$ ) 50 to 60 Hz	115 V AC/DC ( $\pm 10\%$ ) 50 to 60 Hz	24 V AC ( $\pm 10\%$ ) 50 to 60 Hz
Power consumption	Inrush	3 W	3 W	9.5 VA/3 W	9.5 VA
	Holding	3 W	3 W	5 VA/3 W	5 VA
Duty cycle		100 %			
Ambient temperature in temperature class (max. cable temperature)	T6	-60 to +40 °C	-	-	-
	T5	-60 to +55 °C	-60 to +55 °C	-60 to +55 °C (-970 only)	-
	T4	-60 to +65 °C (85 °C) -60 to +80 °C (105 °C)	-	-60 to +40 °C (90 °C) (-960 only)	-60 to +40 °C (90 °C)
	T3	-	-	-60 to +55 °C (105 °C) (-960 only)	-60 to +55 °C (105 °C)
Connection		Female thread M20x1.5			

Pneumatic data for pilot valve		
Type	3962-9	
Supply air	Medium	Instrument air
	Pressure	1.4 to 10 bar
Output signal	Same pressure as pilot supply	
Air consumption	No air consumption	
$K_{VS}$ coefficient	0.05	
Switching time	30 ms	
Control pressure connection	CNOMO interface	

## Technical data

<b>Booster valve, actuated on one side, <math>K_{VS}</math> 4.3, with threaded connections</b>			
Switching function	3/2-way function	5/2-way function	6/2-way function
$K_{VS}$ <sup>1)</sup> (direction of flow)	1.9 (4→3), 1.5 (3→4), 4.3 (3→5), 4.7 (5→3)		
Design	Poppet valve with diaphragm actuator, soft seated, with return spring		
Material	Enclosure	Aluminum, powder coated, gray beige RAL 1019 or stainless steel 1.4404	
	Diaphragms	Chloroprene rubber (-20 to +80 °C) or silicone rubber (-45 to +80 °C)	
	Seals	Chloroprene rubber (-20 to +80 °C) or silicone rubber (-45 to +80 °C)	
	Springs	Stainless steel 1.4310	
	Screws	Stainless steel 1.4571	
Actuation	Controlled on one side with a pilot valve		
Operating medium	Instrument air (free from corrosive substances) or nitrogen <sup>2)</sup> , Instrument air (free from corrosive substances), air containing oil or non-corrosive gases <sup>3)</sup>		
Compressed air quality according to ISO 8573-1	Particle size and density: Class 4 · Oil content: Class 3 · Pressure dew point: Class 3 or at least 10 K below the lowest ambient temperature to be expected		
Max. operating pressure <sup>4)</sup>	10.0 bar		
Output signal	Operating pressure		
Pneumatic connection	G ½ or ½ NPT		
Ambient temperature <sup>5)</sup>	-20 to +80 °C, -45 to +80 °C		
Approx. weight	585 g	1100 g	

<sup>1)</sup> The air flow rate when  $p_1 = 2.4$  bar and  $p_2 = 1.0$  bar is calculated using the following formula:

$$Q = K_{VS} \times 36.22 \text{ in m}^3/\text{h.}$$

<sup>2)</sup> With internal pilot supply

<sup>3)</sup> With external pilot supply

<sup>4)</sup> To control the booster valve in the reversed direction of flow (3→4), the pilot supply pressure must be higher than the operating pressure.

<sup>5)</sup> The permissible ambient temperature of the solenoid valve depends on the permissible ambient temperature of the components, types of protection and temperature class.

Booster valve, actuated on one side, $K_{VS}$ 2.0 or 4.3, with NAMUR interface			
Switching function		3/2-way function with exhaust air feedback	
$K_{VS}$ <sup>1)</sup> (direction of flow)		1.1 (4→3) 2.0 (3→5)   1.9 (4→3) 4.3 (3→5)	
Design			
Material		Poppet valve with diaphragm actuator, soft seated, with return spring	
Enclosure	Aluminum, powder coated, gray beige RAL 1019 or stainless steel 1.4404		
Diaphragms	Chloroprene rubber (-20 to +80 °C) or silicone rubber (-45 to +80 °C)		
Seals	Chloroprene rubber (-20 to +80 °C) or silicone rubber (-45 to +80 °C)		
Springs	Stainless steel 1.4310		
Screws	Stainless steel 1.4571		
Actuation			
Controlled on one side with a pilot valve			
Operating medium			
Instrument air (free from corrosive substances) or nitrogen <sup>2)</sup> , Instrument air (free from corrosive substances), air containing oil or non-corrosive gases <sup>3)</sup>			
Compressed air quality according to ISO 8573-1			
Particle size and density: Class 4 · Oil content: Class 3 · Pressure dew point: Class 3 or at least 10 K below the lowest ambient temperature to be expected			
Max. operating pressure			
10.0 bar			
Output signal			
Operating pressure			
Pneumatic connection	Supply air	G ¼ or ¼ NPT and NAMUR interface ¼" <sup>4)</sup> with G ¾ / ¾ NPT	G ½ or ½ NPT and NAMUR interface ½" <sup>4)</sup>
	Exhaust air	G ½ or ½ NPT and NAMUR interface ¼" <sup>4)</sup> with G ¾ / ¾ NPT	G ½ or ½ NPT and NAMUR interface ½" <sup>4)</sup>
Ambient temperature <sup>5)</sup>			
-20 to +80 °C, -45 to +80 °C			
Approx. weight		1380 g	1500 g

<sup>1)</sup> The air flow rate when  $p_1 = 2.4$  bar and  $p_2 = 1.0$  bar is calculated using the following formula:

$$Q = K_{VS} \times 36.22 \text{ in m}^3/\text{h.}$$

<sup>2)</sup> With internal pilot supply

<sup>3)</sup> With external pilot supply

<sup>4)</sup> NAMUR interface according to VDI/VDE 3845

<sup>5)</sup> The permissible ambient temperature of the solenoid valve depends on the permissible ambient temperature of the components, types of protection and temperature class.

## Technical data

<b>Booster valve, actuated on one side, <math>K_{VS}</math> 1.4 or 2.9<sup>1)</sup>, with threaded connections or NAMUR interface</b>		
Switching function	3/2-way function with exhaust air feedback	5/2-way function
$K_{VS}$ <sup>2)</sup>	1.4 or 2.9 <sup>1)</sup>	
Design	Spool, metal-to-metal seat, zero overlap, with return spring	
Material	Enclosure	Aluminum, powder coated, gray beige RAL 1019 or stainless steel 1.4404
	Seals	Silicone rubber
	Filter	Polyethylene
	Screws	Stainless steel 1.4571
Actuation	Controlled on one side with a pilot valve	
Operating medium	Instrument air (free from corrosive substances) or nitrogen <sup>3)</sup> , Instrument air (free from corrosive substances), air containing oil or non-corrosive gases <sup>4)</sup>	
Compressed air quality according to ISO 8573-1	Particle size and density: Class 4 · Oil content: Class 3 · Pressure dew point: Class 3 or at least 10 K below the lowest ambient temperature to be expected	
Max. operating pressure	10.0 bar	
Output signal	Operating pressure	
Pneumatic connection	G 1/4 or 1/4 NPT and NAMUR interface 1/4" <sup>5)</sup> ( $K_{VS}$ 1.4) G 1/2 or 1/2 NPT and NAMUR interface 1/2" <sup>5)</sup> ( $K_{VS}$ 2.9)	
Ambient temperature <sup>6)</sup>	-45 to +80 °C	
Approx. weight	485 kg ( $K_{VS}$ 1.4)	
	1760 kg ( $K_{VS}$ 2.9)	

<sup>1)</sup> On request, no SIL.

<sup>2)</sup> The air flow rate when  $p_1 = 2.4$  bar and  $p_2 = 1.0$  bar is calculated using the following formula:

$$Q = K_{VS} \times 36.22 \text{ in m}^3/\text{h.}$$

<sup>3)</sup> With internal pilot supply

<sup>4)</sup> With external pilot supply

<sup>5)</sup> NAMUR interface according to VDI/VDE 3845

<sup>6)</sup> The permissible ambient temperature of the solenoid valve depends on the permissible ambient temperature of the components, types of protection and temperature class.

## 3 Safety-related functions

### Emergency venting

The solenoid valve is energized by a binary voltage signal. Fail-safe action is triggered when no voltage signal (0 V AC/DC) is applied to terminals + and -. The solenoid valve vents to the atmosphere and the actuator is vented as well (see Fig. 1).

### 3.1 Fail-safe action

Fail-safe action is triggered by the solenoid valve and upon supply air failure.

The solenoid valve fully discharges its pneumatic output to the atmosphere, causing the mounted actuator to be vented. As a result, the valve moves to the fail-safe position.

The fail-safe position depends on how the springs are arranged in the pneumatic actuator (air-to-close or air-to-open).

## 4 Mounting, connection and start-up

Refer to Mounting and Operating Instructions ► EB 3962-9 on how to mount the solenoid valve, perform the electric and pneumatic connections as well as start up the solenoid valve. Only use original mounting parts and accessories.

## Safety-related functions

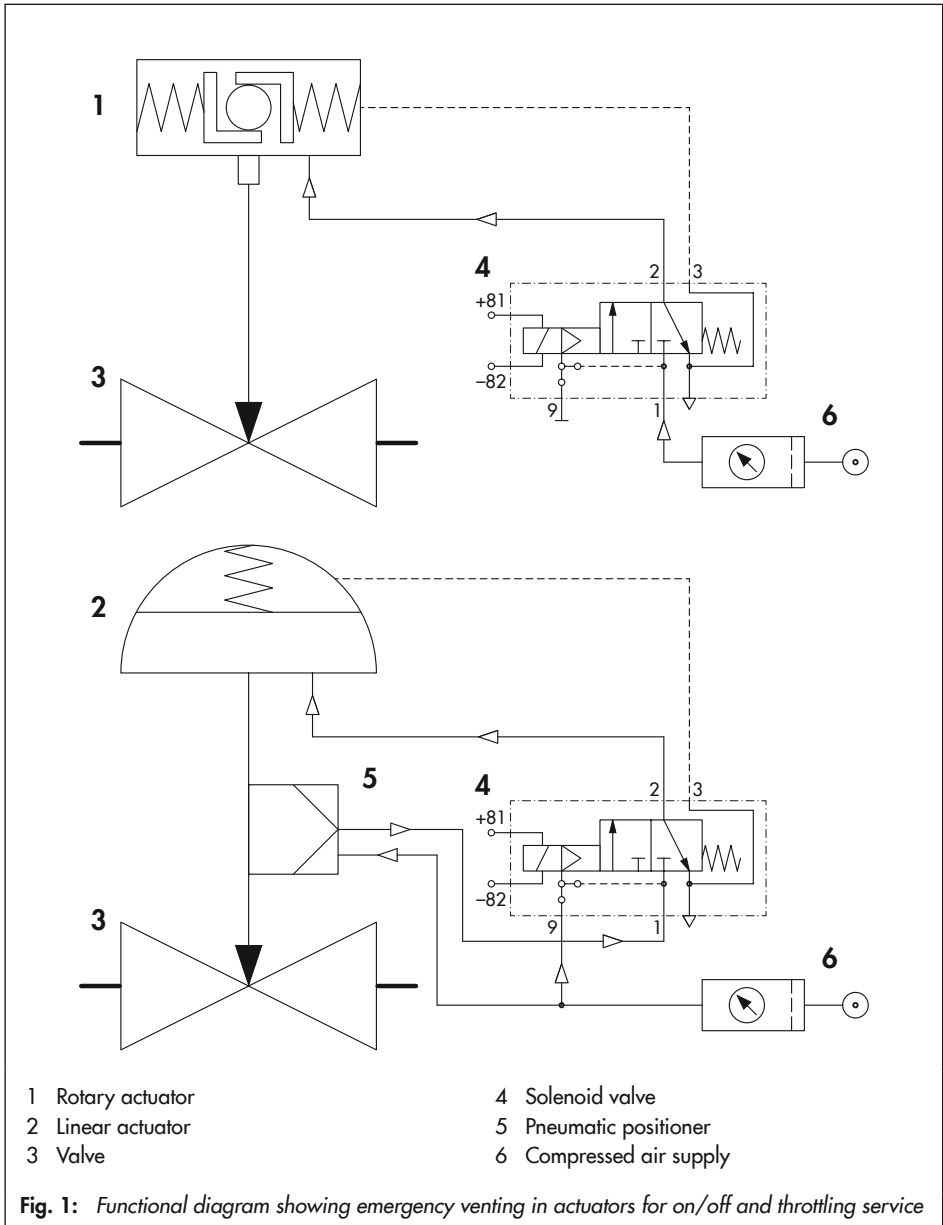

## 5 Required conditions

### **⚠ WARNING**

**Risk of malfunction due to incorrect selection or wrong installation and operating conditions.**

→ Only use control valves in safety-instrumented systems if the necessary conditions in the plant are fulfilled. This also applies to the mounted solenoid valve.

### 5.1 Selection

- The required transit times of the control valve are observed.  
The transit times to be implemented are determined by the process engineering requirements.
- The solenoid valve is suitable for the prevailing ambient temperature.

Versions	Temperature range
With diaphragm and seals made of chloroprene rubber	-20 to +40 °C
With diaphragm and seals made of silicone rubber	-45 to +40 °C
With plastic cable gland	-20 to +40 °C
With metal cable gland	-45 to +40 °C
<b>The specifications in the test certificates additionally apply to explosion-protected versions.</b>	

- The temperature limits are observed.

### 5.2 Mechanical and pneumatic installation

- The solenoid valve is mounted properly as described in the mounting and operating instructions and connected to the air supply.
- The maximum supply pressure does not exceed 10.0 bar.
- The supply air meets the instrument air specifications.

Particle size and quantity	Oil content	Pressure dew point
Class 4	Class 3	Class 3
≤5 µm and 1000/m <sup>3</sup>	≤1 mg/m <sup>3</sup>	-20 °C or at least 10 K below the lowest ambient temperature to be expected

## Required conditions



### Tip

We recommend installing a supply pressure regulator/filter upstream of the device. For example, Type 3999-009x Service Unit or Type 3999-0096 Filter Regulator can be used.

---

- The minimum required cross section of the connecting lines is observed: 4 mm inside diameter for the external pilot supply line (9) and 9 mm inside diameter for the internal pilot supply line (4).  
See "Sizing of the connecting line" in the mounting and operating instructions  
▶ EB 3962-9.
- Select the cross section and length of the line to ensure that the supply pressure at the device on supplying air does not fall below the minimum limit of 1.4 bar.
- The solenoid valve is mounted as prescribed.
- The exhaust opening at the solenoid valve remains open when the solenoid valve is installed on site.

## 5.3 Electrical installation

- The solenoid valve is mounted properly as described in the mounting and operating instructions and connected to the electric power supply.
- Only cables whose outside diameters are suitable for the cable glands are used.
- The cable glands and enclosure cover screws are fastened tightly to ensure that the degree of protection is met.
- The installation requirements for the applicable explosion protection measures are observed.
- The special conditions specified in the explosion protection certificates are observed.



## 6 Proof testing

The proof test interval and the extent of testing lie within the operator's responsibility. The operator must draw up a test plan, in which the proof tests and the interval between them are specified. We recommend summarizing the requirements of the proof test in a check-list.

---

### **⚠ WARNING**

***Risk of dangerous failure due to malfunction in the event of emergency (actuator is not vented or the valve does not move to the fail-safe position).***

→ *Only use devices in safety-instrumented systems that have passed the proof test according to the test plan drawn up by the operator.*

---

Regularly check the safety-instrumented function of the entire SIS loop. The test intervals are determined, for example on calculating each single SIS loop in a plant ( $PFD_{avg}$ ).

### 6.1 Function testing

Regularly check the safety function according to the test plan drawn up by the operator.

Refer to the SIL proof test when large deviations occur or any other irregularities. The necessary documentation for this is provided by SAMSON.

The SIL proof test can be performed by SAMSON on request.

---

### **i Note**

*Record any device faults and e-mail ([aftersaleservice@samsongroup.com](mailto:aftersaleservice@samsongroup.com)) them to SAMSON.*

---

## Proof testing

- In case of internal pilot supply, air with the permissible operating pressure from 1.4 to 8.0 bar is applied to port 4.  
In case of external pilot supply, air with the maximum operating pressure of 10.0 bar or the maximum available operating pressure must be applied to port 9. On using an up-stream positioner, adjust it so that the maximum output pressure is available at the positioner output.
  - Apply the nominal voltage  $U_N$  specified on the nameplate to the solenoid valve.
  - Check whether the valve moves to its end position on demand.
  - De-energize the solenoid valve.  
Check whether the actuator is fully vented within the demanded time (fail-safe position).
- 



### Tip

*Connect a pressure gauge to check that the actuator has completely vented.*

---

- Record the valve transit time and compare it to the time the valve took at start-up and during proof tests.

## 6.2 Visual inspection to avoid systematic failure

To avoid systematic failure, inspect the solenoid valve regularly. The frequency and the scope of the inspection lie within the operator's responsibility. Take application-specific influences into account, such as:

- Dirt blocking the pneumatic connections
  - Corrosion (destruction primarily of metals due to chemical and physical processes)
  - Material fatigue
  - Aging (damage caused to organic materials, e.g. plastics or elastomers, by exposure to light and heat)
  - Chemical attack (organic materials, e.g. plastics or elastomer, which swell, leach out or decompose due to exposure to chemicals)
- 

### NOTICE

***Risk of malfunction due to the use of unauthorized parts.***

- *Only use original parts to replace worn parts.*
-

## 7 Repairs

Only perform the work on the solenoid valve described in ► EB 3962-9.

Only use the specified original mounting parts.

## 8 Safety-related data and certificates

The Type 3962-9 Solenoid Valves with SIL marking consist of a Pneumatrol pilot valve EP000/d/TB and a SAMSON Type 3756 Booster Valve. The versions with  $\frac{1}{4}$  NAMUR interface ( $K_{VS}$  2.0) and with  $\frac{1}{2}$  NAMUR interface ( $K_{VS}$  4.3) as well as with  $\frac{1}{2}$  threaded connection for pipe mounting are suitable for use in safety-instrumented systems according to IEC 61508.

The devices have an HFT of 0 and can be used up to SIL 2 (single device, HFT = 0) according to IEC 61511.

Verification must be performed taking into account the following certificates:

- ENGINEERING SAFETY CONSULTANTS no. F127\_CT001 rev. 4
- TÜV Rheinland® no. 968/V 1160.00/20

# Certificate



SIL/PL  
Capability

www.tuv.com  
ID 960000000

No.: 968/V 1160.00/20

<b>Product tested</b>	Electromagnetic control, solenoid, booster valves and electrical position feedback	<b>Certificate holder</b>	SAMSON AG Weismüllerstr. 3 60314 Frankfurt / Main Germany
<b>Type designation</b>	3963, 3967, 3964, 3756, 3701, 3968, 3776 (with option solenoid valve as well as safe indication of end positions )		
<b>Codes and standards</b>	IEC 61508 Parts 1-2 and 4-7:2010		
<b>Intended application</b>	Safety Function: Safe venting (and safe indication of end positions)  The test items are suitable for use in a safety instrumented system up to SIL 2 (low demand mode). Under consideration of the minimum required hardware fault tolerance HFT = 1 the valves may be used in a redundant architecture up to SIL 3 according to IEC 61508 and IEC 61511-1:2016 + AMD1:2017.		
<b>Specific requirements</b>	The instructions of the associated Installation, Operating and Safety Manual shall be considered.		
Summary of test results see back side of this certificate.			
Valid until 2025-05-04			

The issue of this certificate is based upon an examination, whose results are documented in Report No. 968/V 1160.00/20 dated 2020-05-04.  
This certificate is valid only for products which are identical with the product tested.

TÜV Rheinland Industrie Service GmbH  
Bereich Automation  
Funktionale Sicherheit  
Am Grauen Stein, 51105 Köln

Köln, 2020-05-04

Certification Body Safety & Security for Automation & Grid

  
Dipl.-Ing. Gebhard Bouwer

www.fs-products.com  
www.tuv.com

 **TÜVRheinland**<sup>®</sup>  
Precisely Right.

TÜV Rheinland Industrie Service GmbH, Am Grauen Stein, 51105 Köln, Germany  
Tel.: +49 221 6016-1180, Fax: +49 221 6016-5033, E-Mail: [tr@tuev.com](mailto:tr@tuev.com)

Holder: **SAMSON AG**  
 Weismüllerstraße 3  
 60314 Frankfurt am Main  
 Germany

Product tested: Electromagnetic control, solenoid and booster valves of the types  
 3963, 3967, 3964, 3756, 3701, 3968<sup>4</sup>,  
 3776 (with option "solenoid valve" as well as "safe indication of end positions")

#### Results of Assessment

Route of Assessment		2 <sub>H</sub> / 1 <sub>D</sub>
Type of Sub-system		Type A
Mode of Operation		Low Demand Mode

#### Safe venting - Type 3701, 3963, 3967, 3776 (with option solenoid valve)

Hardware Fault Tolerance	HFT	0	
Lambda Dangerous Undetected <sup>1</sup>	$\lambda_{DU}$	8.02 E-08 / h	80 FIT
Average Probability of Failure on Demand <sup>2</sup>	$PFD_{avg}(T_1)$	3.51 E-04	

#### Safe indication of end positions - Type 3776 (only with inductive proximity switches)

Hardware Fault Tolerance	HFT	0	
Lambda Dangerous Undetected <sup>1</sup>	$\lambda_{DU}$	7.35 E-08 / h	74 FIT
Average Probability of Failure on Demand <sup>2</sup>	$PFD_{avg}(T_1)$	3.22 E-04	

#### Safe venting - Type 3756

Hardware Fault Tolerance	HFT	0 (1 as variant, see report)	
Lambda Dangerous Undetected <sup>1</sup>	$\lambda_{DU}$	8.38 E-08 / h	84 FIT
Average Probability of Failure on Demand <sup>2</sup>	$PFD_{avg}(T_1)$	3.67 E-04	
Average Probability of Failure on Demand 100 <sup>2</sup> 3	$PFD_{avg}(T_1)$	3.69 E-05	

#### Safe venting - Type 3964 pilot valve

Hardware Fault Tolerance	HFT	0	
Lambda Dangerous Undetected <sup>1</sup>	$\lambda_{DU}$	5.12 E-09 / h	5 FIT
Average Probability of Failure on Demand <sup>2</sup>	$PFD_{avg}(T_1)$	2.24 E-05	

<sup>1</sup> assumed Diagnostic Coverage DC = 0 %

<sup>2</sup> assumed Proof Test Interval  $T_1$  = 1 year

<sup>3</sup> assumed Proof Test Interval  $T_1$  = 1 year and  $\beta_{1002}$  = 10 %

<sup>4</sup> The solenoid valve manifold of type 3968 is a combination of the control valves 3756 and the pilot valves 3964. The failure rates must be determined for each individual application from the given characteristic values of the single components.

#### Origin of values

The stated failure rates are the result of an FMEDA with tailored failure rates for the design and manufacturing process.

Furthermore the results have been verified by qualification tests and field-feedback data of the last 5 years.

Failure rates include failures that occur at a random point in time and are due to degradation mechanisms such as ageing.

The stated failure rates do not release the end-user from collecting and evaluating application-specific reliability data.

#### Systematic Capability

The development and manufacturing process and the functional safety management applied by the manufacturer in the relevant lifecycle phases of the product have been audited and assessed as suitable for the manufacturing of products for use in applications with a maximum Safety Integrity Level of 3 (SC 3).

#### Periodic Tests and Maintenance

The given values require periodic tests and maintenance as described in the Safety Manual.

The operator is responsible for the consideration of specific external conditions (e.g. ensuring of required quality of media, max. temperature, time of impact), and adequate test cycles.



---

## IEC 61508 Safety Integrity Level Capability Certificate

---

### *Functional Safety of Safety-Related Programmable Electronic Systems*

The **Pneumatrol Ltd, Solenoid Valves Series C, E and T** have been assessed and is considered capable for use in a low demand Safety Function up to (and including) SIL 1 / 2 with respect to random hardware failures, architectural constraints and Systematic Capability.

The assessment was based on the assumptions, data provided, and recommendations given in:

- **Environmental Resources Management Ltd Report: F127\_SV001 rev. 4;**
- **Renewal letter from Pneumatrol Ltd, signed by Jamie C Dummer, Managing Director, dated: 18/05/2023.**

The products were assessed against its ability to move the valve to the designated safe state within the specified time for both De-Energise To Trip (DETT) and Energise To Trip (ETT).

The assessment was carried out to determine compliance with IEC 61508 (2010 Edition) with regards to:

- DETT: SIL 2 with a HFT = 0 via Route 1x;
- DETT: SIL 3 with a HFT = 1 via Route 1x;
- ETT: SIL 1 with a HFT = 0 via Route 1x;
- ETT: SIL 2 with a HFT = 1 via Route 1x;
- Architectural Constraints;
- Systematic Capability of SIL 2 against IEC 61508 (2010 Edition) Route 2s.

Note 1: The SIL of a complete SIF (sensor, logic solver and final element subsystems) must be verified to calculate the required PFD / PFH, considering any redundancy, Proof Test Interval (PTI), Proof Test Coverage (PTC), Mission Time and Mean Time To Restoration (MTTR) for all elements included in the SIF. Each subsystem should be verified to ensure compliance with the minimum HFT requirements.

**IMPORTANT:** It should be noted that this assessment does not include confirmation of the response time of the devices. For response times (along with any relevant assumptions) reference should be made to the Safety Manual of each device and the total SIF response time **MUST** be compared against the process safety time for the specific application.



Partner: Simon Burwood  
Assessment Date: March 2017  
Renewal Date: June 2023, valid to June 2025  
Certificate: F127\_CT001 rev. 7

Page 1 of 2

ENVIRONMENTAL RESOURCES MANAGEMENT LTD  
2nd Floor, Exchequer Court, 33 St. Mary Axe,



Model Series	Failure Mode	$\lambda_{EM}$ (/hr)	$\lambda_{EO}$ (/hr)	$\lambda_E$ (/hr)	SFF	Type	Achieved SIL (Arch. Constraints, HFT = 0)	Achieved SIL (Arch. Constraints, HFT = 1)
C Series + Terminal Box EXN	De-Energised to Trip	7.2E-08	0.0E+00	3.9E-07	85%	A	2	3
	Energised to Trip	3.7E-07	0.0E+00	7.0E-08	2%	A	1	2
C Series + Terminal Box EXM	De-Energised to Trip	7.2E-08	0.0E+00	4.0E-07	85%	A	2	3
	Energised to Trip	3.7E-07	0.0E+00	7.0E-08	2%	A	1	2
C Series + Terminal Box IA	De-Energised to Trip	7.2E-08	0.0E+00	4.0E-07	85%	A	2	3
	Energised to Trip	3.7E-07	0.0E+00	9.0E-08	3%	A	1	2
E Series + Terminal Box EXN	De-Energised to Trip	7.2E-08	0.0E+00	4.0E-07	85%	A	2	3
	Energised to Trip	3.7E-07	0.0E+00	7.0E-08	2%	A	1	2
E Series + Terminal Box EXM	De-Energised to Trip	7.2E-08	0.0E+00	4.0E-07	85%	A	2	3
	Energised to Trip	3.7E-07	0.0E+00	7.0E-08	2%	A	1	2
E Series + Terminal Box IA	De-Energised to Trip	7.2E-08	0.0E+00	4.0E-07	85%	A	2	3
	Energised to Trip	3.7E-07	0.0E+00	9.0E-08	3%	A	1	2
T Series + Terminal Box EXN	De-Energised to Trip	7.2E-08	0.0E+00	3.9E-07	85%	A	2	3
	Energised to Trip	3.7E-07	0.0E+00	7.0E-08	2%	A	1	2
T Series + Terminal Box EXM	De-Energised to Trip	7.2E-08	0.0E+00	4.0E-07	85%	A	2	3
	Energised to Trip	3.7E-07	0.0E+00	7.0E-08	2%	A	1	2
T Series + Terminal Box IA	De-Energised to Trip	7.2E-08	0.0E+00	4.0E-07	85%	A	2	3
	Energised to Trip	3.7E-07	0.0E+00	9.0E-08	3%	A	1	2

Page 2 of 2

ENVIRONMENTAL RESOURCES MANAGEMENT LTD  
 2nd Floor, Exchequer Court, 33 St. Mary Axe,  
 London, EC3A 8AA UK  
 Telephone: +44 (0)20 8542 2807  
 Registered in England and Wales: 7006608  
 Registered Office: 33 St. Mary Axe, London, EC3A 8AA

SH 3962-9 EN



SAMSON AKTIENGESELLSCHAFT  
Weismüllerstraße 3 · 60314 Frankfurt am Main, Germany  
Phone: +49 69 4009-0 · Fax: +49 69 4009-1507  
samson@samsongroup.com · www.samsongroup.com