

## T 2549 EN

### Type 2422/2425 Excess Pressure Valve Self-operated Pressure Regulators



#### Application

Pressure regulators for set points from **0.05 to 2.5 bar** · Nominal sizes **DN 125 to 250**<sup>1)</sup> · Pressure rating **PN 16 to 40** · Suitable for liquids, gases and vapors up to **350 °C**

The valve **opens** when the **upstream** pressure **rises**.

The excess pressure valves, consisting of a valve and actuator, control the upstream pressure to an adjustable set point. The medium pressure to be kept constant is transmitted through a control line to the diaphragm of the actuator and consequently the valve plug.

#### Special features

- Low-maintenance, medium-controlled proportional regulators requiring no auxiliary energy
- Wide set point range and convenient set point adjustment using a nut
- Exchangeable set point springs and actuator
- Spring-loaded, single-seated valve with upstream and downstream pressures balanced by a stainless steel bellows or by a balancing diaphragm
- Reduced  $K_{VS}$  coefficients to adapt the regulator to the operating conditions
- Standard low-noise plug · Special version with flow divider ST 1 or ST 3 for further noise level reduction. See Data Sheet ▶ T 8081.

#### Versions

##### Type 2422/2425 Excess Pressure Valve for DN 125 to 250

Consisting of:

Type 2422 Valve balanced by a bellows or a diaphragm with soft-seated plug · Body of cast iron, spheroidal graphite iron, cast steel or cast stainless steel · Type 2425 Actuator with EPDM rolling diaphragm



Fig. 1: Type 2422/2425 Excess Pressure Valve

#### Special versions

- With flow divider ST 1 or ST 3 for particularly low-noise operation
- With metal-seated plug
- With FKM rolling diaphragm, e.g. for mineral oils or flammable gases
- With NBR rolling diaphragm for flammable gases
- Version completely in stainless steel for pressure rating PN 16 to 40 · Details on request
- Actuator with two diaphragms
- With metal cover to protect the set point springs

<sup>1)</sup> Valves larger than DN 250 on request

**Principle of operation** (see Fig. 2)

The medium flows through the valve in the direction indicated by the arrow. The position of the plug (3) determines the flow rate across the area released between plug (3) and valve seat (2). The plug stem (5) with the plug is connected to the actuator stem (11) of the actuator (10).

The upstream pressure  $p_1$  is regulated by the set point springs (7) and the set point adjuster (6). When relieved of pressure, the valve is closed by the force of the set point springs.

The upstream pressure  $p_1$  to be controlled is tapped upstream of the valve and transmitted over the control line to the operating diaphragm (12) where it is converted into a positioning force. This force is used to move the valve plug (3) according to the force of the set point springs. The spring force is adjustable at the set point adjuster (6).

Regulators balanced by a bellows or a diaphragm only differ in the pressure balancing principle applied. The valves balanced by a diaphragm have a balancing diaphragm (4.2) instead of a bellows (4.1). In both cases, the forces created by the upstream and downstream pressures that act on the valve plug are balanced out.

The valves can be supplied with flow divider ST 1 or ST 3. The valve seat must be replaced on retrofitting the flow divider.

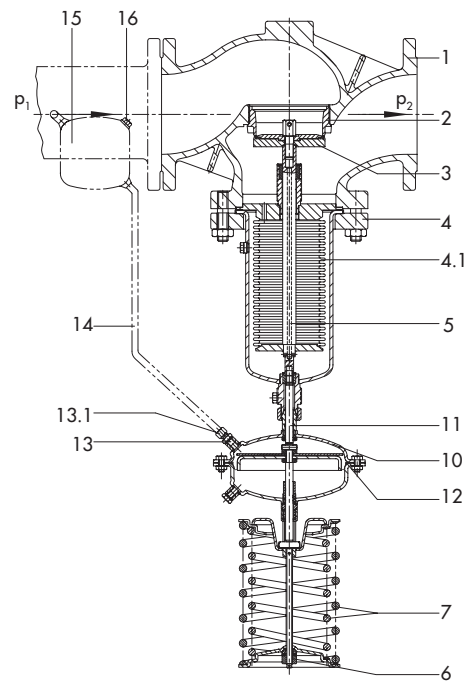

Type 2422/2425 Excess Pressure Valve  
Type 2422 Valve · Balanced by a bellows

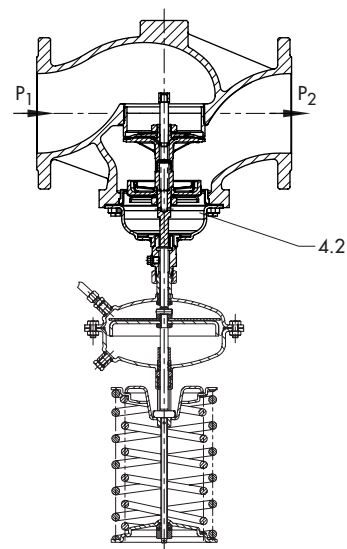

Type 2422/2425 Excess Pressure Valve  
Type 2422 Valve · Balanced by a diaphragm

**Legend**

1 Valve body	12 Operating diaphragm
2 Seat	13 Control line connection G 1/4
3 Plug	13.1 Screw joint with restriction
4 Bellows housing	14 Control line (to be mounted on site)
4.1 Balancing bellows	15 Compensation chamber
4.2 Balancing diaphragm	16 Filler plug
5 Plug stem	P <sub>1</sub> Upstream pressure
6 Set point adjuster	P <sub>2</sub> Downstream pressure
7 Set point springs	
10 Actuator	
11 Actuator stem	

**Fig. 2:** Functional diagram

**Table 1: Technical data · All pressures in bar (gauge)**

Type 2422 Valve		DN 125	DN 150	DN 200	DN 250
Nominal size					
Pressure rating		PN 16, 25 or 40			
Max. permissible temperature	Body	See pressure-temperature diagram in ► T 2500			
	Valve plug balanced by a bellows	Metal seal: max. 350 °C · PTFE soft seal: max. 220 °C · EPDM or FKM soft seal: max. 150 °C · NBR soft seal: max. 80 °C			
	Valve plug balanced by a diaphragm	150 °C			
Leakage class according to IEC 60534-4		≤0.05 % of $K_{VS}$ coefficient			
Conformity		<b>CE</b>			
Type 2425 Actuator					
Set point ranges		0.05 to 0.25 bar · 0.1 to 0.6 bar · 0.2 to 1 bar · 0.5 to 1.5 bar · 1 to 2.5 bar <sup>1)</sup>			
Max. perm. pressure at actuator	Actuator area	320 cm <sup>2</sup>		640 cm <sup>2</sup>	
	Pressure	3 bar		1.5 bar	
Max. permissible temperature		Gases at the actuator 80 °C · Liquids 150 °C, with compensation chamber 350 °C · Steam with compensation chamber 350 °C			

<sup>1)</sup> Set point ranges above 2.5 bar ► T 2552 (Type 2335 Excess Pressure Valve)

**Table 2: Materials · Material numbers according to DIN EN**

Type 2422 Valve · Balanced by a bellows				
Pressure rating	PN 16	PN 25	PN 16, 25 and 40	
Valve body	Cast iron EN-GJL-250	Spheroidal graphite iron EN-GJS-400-18-LT	Cast steel 1.0619	Stainless steel 1.4408
Seat	1.4006			1.4404
Plug	1.4404			1.4404 with PTFE seal
Seal for soft-seated plug	PTFE · EPDM · FKM · NBR			
Plug stem	1.4301			
Metal bellows	1.4571			
Bottom section	1.0305			1.4571
Body gasket	Graphite on metal core			
Type 2422 Valve · Balanced by a diaphragm				
Pressure rating	PN 16	PN 16/25	PN 16, 25 and 40	
Valve body	Cast iron EN-GJL-250	Spheroidal graphite iron EN-GJS-400-18-LT	Cast steel 1.0619	Stainless steel 1.4408
Valve seat	Red brass <sup>1)</sup>			
Plug Standard version	Red brass <sup>1)</sup> · With EPDM soft seal or with PTFE soft seal			
Pressure balancing	Balancing cases made of sheet steel DD11 · EPDM balancing diaphragm for liquids and non-flammable gases or NBR diaphragm for flammable gases			
Gasket	Graphite on metal core			
Type 2425 Actuator				
Diaphragm cases	DD 11			1.4301
Diaphragm	EPDM with fabric reinforcement · FKM · NBR			
Guide bushing	DU bushing			PTFE
Seals	EPDM · FKM · NBR			

<sup>1)</sup> Special version: 1.4409

**Table 3: Valve balanced by a bellows ·  $K_{VS}$  coefficients and max. perm. differential pressures  $\Delta p$** 

Type 2422 Valve · Balanced by a bellows				
$K_{VS}$ coefficients and max. permissible differential pressures $\Delta p$				
DN	Standard $K_{VS}$ coefficients	Flow divider ST 1 · $K_{VS}$ -ST 1	Flow divider ST 3 · $K_{VS}$ -ST 3	Max. perm. diff. pressure $\Delta p$
125	190	150	95	16 bar
150	280	210	140	12 bar
200	420	315	200	10 bar
250	500	375	220	10 bar
Reduced $K_{VS}$ coefficients and max. permissible differential pressures $\Delta p$				
125	80	60	40	20 bar
150	125	95	60	16 bar
200	280	210	140	12 bar
250	280	210	140	12 bar

**Table 3.1:** Valve balanced by a diaphragm ·  $K_{VS}$  coefficients and max. perm. differential pressures  $\Delta p$

Type 2422 Valve · Balanced by a diaphragm				
$K_{VS}$ coefficients and max. permissible differential pressures $\Delta p$				
Nominal size	DN 125	DN 150	DN 200	DN 250
$K_{VS}$ coefficient	250	380	650	800
Max. perm. differential pressure $\Delta p$	12 bar		10 bar	

**Dimensions**

**Type 2422 Valve · Balanced by a bellows**

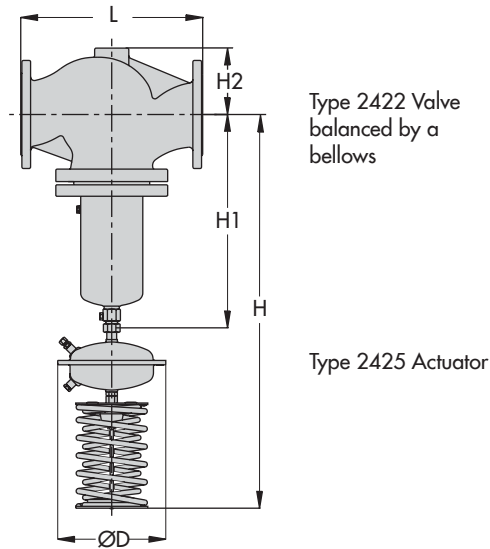

**Fig. 3:** Dimensional drawing of Type 2422 Valve balanced by a bellows with Type 2425 Actuator

**Table 4:** Dimensions in mm and weights · Type 2422 Valve balanced by a bellows

Type 2422/2425 · Balanced by a bellows					
Nominal size	DN 125	DN 150	DN 200	DN 250	
Valve dimensions	Length L	400	480	600	730
	Height H1	460 · 600 <sup>2)</sup>	570 · 730 <sup>2)</sup>	730 · 870 <sup>2)</sup>	
	Height H2	145	175	270	
<b>Set points</b>	<b>Valve with actuator</b>				
<b>0.05 to 0.25 bar</b>	Height H	990	1120 · 1260 <sup>2)</sup>	1260 · 1400 <sup>2)</sup>	
	Actuator	ØD = 390 mm, A = 640 cm <sup>2</sup>			
<b>0.1 to 0.6 bar</b>	Height H	990 · 1130 <sup>2)</sup>	1120 · 1260 <sup>2)</sup>	1260 · 1400 <sup>2)</sup>	
	Actuator	ØD = 390 mm, A = 640 cm <sup>2</sup>			
<b>0.2 to 1.0 bar</b>	Height H	990 · 1130 <sup>2)</sup>	1120 · 1260 <sup>2)</sup>	1260 · 1400 <sup>2)</sup>	
	Actuator	ØD = 390 mm, A = 640 cm <sup>2</sup>			
<b>0.5 to 1.5 bar</b>	Height H	940 · 1080 <sup>2)</sup>	1070 · 1210 <sup>2)</sup>	1210 · 1350 <sup>2)</sup>	
	Actuator	ØD = 285 mm, A = 320 cm <sup>2</sup>			
<b>1 to 2.5 bar</b>	Height H	940 · 1080 <sup>2)</sup>	1070 · 1210 <sup>2)</sup>	1210 · 1350 <sup>2)</sup>	
	Actuator	ØD = 285 mm, A = 320 cm <sup>2</sup>			
<b>Weight<sup>1)</sup>, approx.</b>	92 kg	135 kg	277 kg	322 kg	

<sup>1)</sup> The weight applies to the version with the material specifications EN-GJL-250/PN 16. Add +10 % for all other materials.

<sup>2)</sup> Suitable for temperatures above 220 °C and up to 350 °C

## Dimensions

### Type 2422 Valve · Balanced by a diaphragm

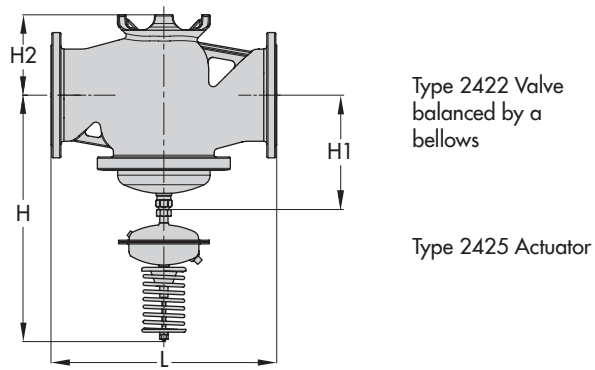

Fig. 4: Dimensional drawing of Type 2422 Valve balanced by a diaphragm with Type 2425 Actuator

Table 5: Dimensions in mm and weights · Type 2422 Valve balanced by a diaphragm

Type 2422/2425 · Balanced by a diaphragm				
Nominal size	DN 125	DN 150	DN 200	DN 250
Length L	400	480	600	730
Height H1	285	310	380	
Height H2	145	175	260	
<b>Set points</b>	<b>Valve with actuator</b>			
<b>0.05 to 0.25 bar</b>	Height H	815	840	910
	Actuator	ØD = 390 mm · A = 640 cm <sup>2</sup>		
<b>0.1 to 0.6 bar</b>	Height H	815	840	910
	Actuator	ØD = 390 mm · A = 640 cm <sup>2</sup>		
<b>0.2 to 1 bar</b>	Height H	765	790	860
	Actuator	ØD = 285 mm · A = 320 cm <sup>2</sup> <sup>1)</sup>		
<b>0.5 to 1.5 bar</b>	Height H	765	790	860
	Actuator	ØD = 285 mm · A = 320 cm <sup>2</sup> <sup>1)</sup>		
<b>1 to 2.5 bar</b>	Height H	765	790	860
	Actuator	ØD = 225 mm · A = 320 cm <sup>2</sup>		
<b>Weight <sup>2)</sup>, approx.</b>	75 kg	95 kg	250 kg	270 kg

<sup>1)</sup> Optionally with 640 cm<sup>2</sup> actuator

<sup>2)</sup> The weight applies to the version with the material specifications EN-GJL-250/PN 16. Add +10 % for all other materials.

## Installation

- Install valves (balanced by a bellows or diaphragm) with the actuator suspended downward.
- Install pipelines horizontally with a slight downward slope on both sides of the valve to prevent condensed water from collecting.
- The direction of flow must match the direction indicated by the arrow on the body.
- Connect a control line to the actuator from the point of pressure tapping located approx. 1 m upstream of the valve in the pipe wall or at the point of measurement of the connected plant (with compensation chamber, if applicable).



## Accessories

- Screw joints with restriction for connection of the control line (e.g. 6 or 12 mm pipe).
- Only applicable to valves balanced by a bellows: compensation chamber for condensation and to protect the operating diaphragm against extreme temperatures. The chamber is required for steam and liquids above 150 °C.

For detailed information on accessories refer to Data Sheet

► T 2595

## Ordering text

**Type 2422/2425** Excess Pressure Valve

DN ...

Body material ..., PN ...

$K_{VS}$  coefficient ..., set point range ... bar

Balanced by a bellows or diaphragm

Optionally, special version ..., accessories ...