

T 8086 EN

Series 240, 250 and SMS · Valves with perforated plug

DIN and ANSI versions

Application

Optimized trim for critical conditions in applications

Nominal size	DN 25 to 500 · NPS 1 to 20
Pressure rating	PN 16 to 400 · Class 150 to 2500
Medium temperature	-273 to +550 °C · -459 to +1022 °F

The perforated plug is mainly used for valves in steam applications, particularly for operation in the wet steam region. Additional fields of application include the control of two-phase medium flow, liquid media which vaporize on the outlet side (flashing valves) or emergency relief valves (blow-off valves) involving gas relief in which flow velocities lower than 0.3 Mach cannot be kept.

Special features

- Use in Series 240, 250 and SMS Valves with body material 1.0619/A216 WCC or higher grade steels
- Combined with seats of Series 240, 250 and SMS Valves
- Permissible actuator forces correspond to those of standard valve trims
- Avoid using media containing solids

Versions

Valves with leakage class IV

- **Type 3241** · Globe valve up to DN 300 and PN 40 (NPS 12, Class 300) · Trim and characteristic according to Table 1 · See Data Sheets ▶ T 8015/▶ T 8012
- **Type 3248** · Cryogenic valve with globe or angle-pattern body up to DN 150 and PN 100 (NPS 6, Class 600) · See Table 1 and Table 2 · See Data Sheets ▶ T 8093/▶ T 8093-1
- **Type 3251** (Fig. 1) · Globe valve up to DN 500 and PN 400 (NPS 20, Class 2500) · See Table 3 · See Data Sheets ▶ T 8051/▶ T 8052
- **Type 251GR** · Globe valve up to DN 300 and PN 160 (NPS 12, Class 900) · See Table 4 · See Data Sheets ▶ T 8003-GR/▶ T 8004-GR
- **Type 251AR** · Angle valve up to DN 200 and PN 160 (NPS 8, Class 900) · See Table 4 · See Data Sheets ▶ T 8003-AR/▶ T 8004-AR

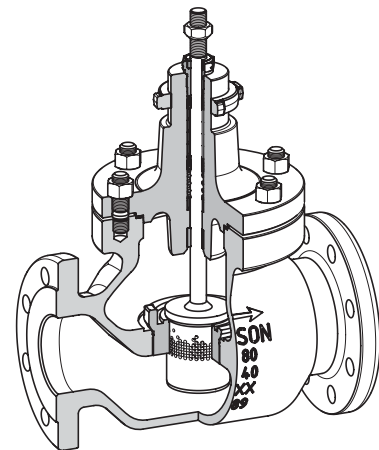

Fig. 1: Type 3251 Globe Valve with perforated plug

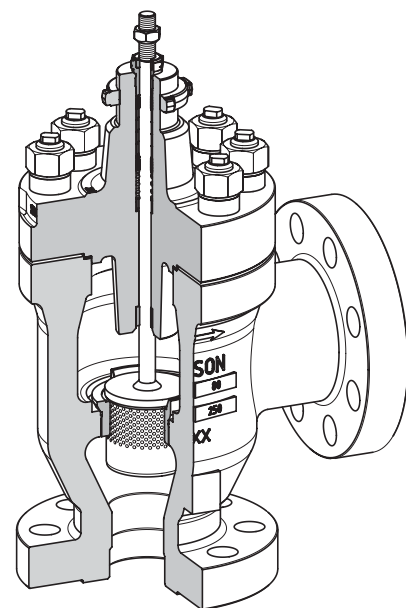

Fig. 2: Type 3256 Angle Valve with perforated plug

- **Type 3254** · Globe valve up to DN 500 and PN 400 (NPS 20, Class 2500) · See Table 5 · See Data Sheets
▶ T 8060/▶ T 8061
- **Type 3256** (Fig. 2) · Angle valve up to DN 300 and PN 400 (NPS 12, Class 2500) · See Table 3 to Table 6 · See Data Sheets ▶ T 8065/▶ T 8066

Options

- **Higher leakage classes** on request
- **Perforated plug for Type 3246** on request

Principle of operation

The medium flows through the perforated plug, splitting up the jet stream into numerous smaller jets to ensure low-noise energy transfer to the surrounding medium.

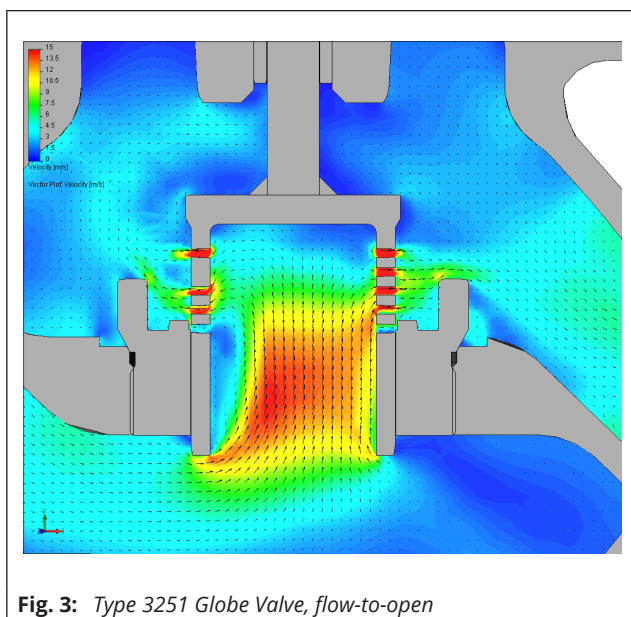

Fig. 3: Type 3251 Globe Valve, flow-to-open

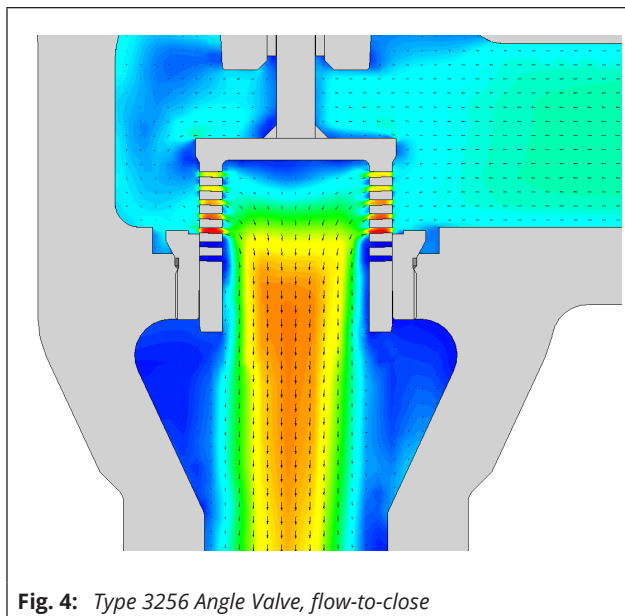

Fig. 4: Type 3256 Angle Valve, flow-to-close

Technical data

Perforated plug	DIN	ANSI
Nominal size (depending on valve type)	DN 25 to 500	NPS 1 to 20
Pressure rating (depending on valve type)	PN 16 to 400	Class 125 to 2500
Medium temperature range (depending on the valve bonnet)	Type 3241 ▶ T 8015/▶ T 8012)	-196 to +450 °C -325 to +842 °F
	Type 3248 ▶ T 8093/▶ T 8093-1)	-273 to +220 °C -459 to +428 °F
	Type 3251/3254 ▶ T 8051/▶ T 8052, ▶ T 8060/▶ T 8061)	-196 to +550 °C -325 to +1022 °F
	Type 251GR/251AR ▶ T 8003-GR/▶ T 8004-GR, ▶ T 8003-AR/▶ T 8004-AR)	-50 to +550 °C -58 to 1022 °F
	Type 3256 ▶ T 8065/▶ T 8066)	-196 to +550 °C -325 to +1022 °F
Max. permissible differential pressure	Same as standard V-port plug, see ▶ T 8000-4	
Direction of flow ¹⁾	Type 3241/3248	Standard FTO
	Type 3251/3254	Standard FTO
	Type 251GR/251AR	Standard FTO
	Type 3256	Standard FTC
Leakage class with metal seal	Class IV according to IEC 60534-4 and DIN EN 1349	Class IV according to ANSI/ FCI 70-2
Characteristic	Equal percentage · Linear	
Rangeability	50:1	
Pressure balancing	See Table 1 to Table 5	
Valve bonnet	Standard · Insulating section · Bellows seal	
Materials		
Seat and plug	Selection depending on application	

¹⁾ FTO: Flow-to-open (flow under the plug) · FTC: Flow-to-close (flow over the plug)

Table 1: Type 3241 Globe Valve and Type 3248 Cryogenic Valve · Direction of flow FTO

Table 1.1: K_{VS} and C_V coefficients for Type 3241 and Type 3248 (up to DN 150/NPS 6) · Equal percentage characteristic

Series 240 · Equal percentage characteristic with direction of flow FTO																					
K_{VS}	4	6.3	10	16	25	36	40	54	63	80	100	120	160	160	250	360	420	630	1000		
C_V	5	7.5	12	20	30	42	47	62	75	95	120	140	190	190	290	420	485	735	1150		
K_{V-1}	3.6	5.7	9	14.5	22	32	36	47	57	72	90	100	144	144	225	320	375	560	900		
C_{V-1}	4.2	7	10.5	17	26	37	42	55	67	85	105	120	170	170	265	375	435	650	1040		
K_{V-2}	-	-	8	13	20	29	-	43	50	63	80	95	125	125	200	290	340	500	800		
C_{V-2}	-	-	9.5	15	23	34	-	50	60	75	95	110	145	145	235	335	390	580	950		
K_{V-3}	-	4.8	7.5	12	20	-	-	40	47	60	75	-	-	120	190	270	315	480	-		
C_{V-3}	-	5.6	9	14	23	-	-	47	55	70	90	-	-	140	220	315	365	560	-		
Seat Ø	mm	24	31	38	48	63	80	63	80	100	110	130	125	150	200	250	300				
Travel	mm	15					30					60					120				
	in	0.59					1.18					2.36					4.72				
Nominal size	DN	NPS	Versions without flow divider · Areas highlighted in gray indicate versions of Type 3241 also available with pressure balancing																		
	25	1	·	·																	
	32	-	·	·	·																
	40	1½	·	·	·	·															
	50	2	·	·	·	·	·														
	65	2½		·	·	·	·	·													
	80	3		·	·	·	·	·	·												
	100	4						·	·	·	·	·									
	125	-						·	·	·	·	·	·								
	150	6						·	·	·	·	·	·	·							
	200	8						·	·	·	·	·	·	·	·	·	·	·	·		
	250	10						·	·	·	·	·	·	·	·	·	·	·	·		
	300	12						·	·	·	·	·	·	·	·	·	·	·	·		
Nominal size	DN	NPS	Versions with flow divider ST 1 · Areas highlighted in gray indicate versions of Type 3241 also available with pressure balancing																		
	25	1																			
	32	-	·	·	·																
	40	1½	·	·	·	·															
	50	2	·	·	·	·	·														
	65	2½		·	·	·	·	·													
	80	3		·	·	·	·	·	·												
	100	4						·	·	·	·	·									
	125	-						·	·	·	·	·	·								
	150	6						·	·	·	·	·	·	·							
	200	8						·	·	·	·	·	·	·	·	·	·	·	·		
	250	10						·	·	·	·	·	·	·	·	·	·	·	·		
	300	12						·	·	·	·	·	·	·	·	·	·	·	·		
Nominal size	DN	NPS	Versions with flow divider ST 2 · Areas highlighted in gray indicate versions of Type 3241 also available with pressure balancing																		
	25	1																			
	32	-		·																	
	40	1½		·	·																
	50	2		·	·																
	65	2½		·	·	·	·														
	80	3		·	·	·	·														
	100	4						·	·	·	·	·									
	125	-						·	·	·	·	·	·								
	150	6						·	·	·	·	·	·	·							
	200	8						·	·	·	·	·	·	·	·	·	·	·	·		
	250	10						·	·	·	·	·	·	·	·	·	·	·	·		
	300	12						·	·	·	·	·	·	·	·	·	·	·	·		
Nominal size	DN	NPS	Versions with flow divider ST 3 · Areas highlighted in gray indicate versions of Type 3241 also available with pressure balancing																		
	25	1																			
	32	-		·																	
	40	1½		·																	
	50	2		·																	
	65	2½		·	·	·	·														
	80	3		·	·	·	·														
	100	4						·													
	125	-						·	·	·											
	150	6						·	·	·	·										
	200	8						·	·	·	·			·	·						
	250	10						·	·	·	·			·	·	·	·				
	300	12						·	·	·	·			·	·	·	·	·	·		

Note:
Specifications do not apply to Type 3248

Note:
Specifications do not apply to Type 3248

Note:
Specifications do not apply to Type 3248

Table 1.2: K_{VS} and C_V coefficients for Type 3241 and Type 3248 (up to DN 150/NPS 6) · Linear characteristic

Series 240 · Linear characteristic with direction of flow FTO																			
K_{VS}	4	6.3	10	16	25	36	47	60	63	100	130	160	210	250	320	500	900	1300	
C_V	5	7.5	12	20	30	42	55	70	75	120	150	190	245	290	375	580	1040	1500	
K_{V-1}	3.6	5.7	9	14.5	22	32	43	54	57	90	115	144	190	225	280	450	800	1150	
C_{V-1}	4.2	7	10.5	17	26	37	50	62	67	105	135	170	220	265	325	520	950	1350	
K_{V-2}			8	13	20	29	38		50	80	105	125	170	200	255	400	720	1040	
C_{V-2}			9.5	15	23	34	45		60	95	120	145	200	235	295	465	835	1200	
K_{V-3}		4.8	7.5	12	20	27			47	75	80			190	230	375	675		
C_{V-3}		5.6	9	14	23	31			55	90	100			220	270	435	780		
Seat Ø	mm	24		31		38		48		63		80		100		110		130	
Travel	mm				15						30				60			120	
	in				0.59						1.18				2.36			4.72	
Nominal size	Versions without flow divider · Areas highlighted in gray indicate versions of Type 3241 also available with pressure balancing																		
DN	NPS																		
25	1	·	·	·	·														
32	-	·	·	·	·														
40	1½	·	·	·	·	·													
50	2	·	·	·	·	·	·												
65	2½		·	·	·	·	·	·											
80	3		·	·	·	·	·	·	·										
100	4									·	·	·							
125	-									·	·	·	·						
150	6									·	·	·	·	·					
200	8									·	·	·	·	·	·	·	·	·	
250	10									·	·	·	·	·	·	·	·	·	·
300	12									·	·	·	·	·	·	·	·	·	·
Nominal size	Versions with flow divider ST 1 · Areas highlighted in gray indicate versions of Type 3241 also available with pressure balancing																		
DN	NPS																		
25	1																		
32	-	·	·	·	·														
40	1½	·	·	·	·	·													
50	2	·	·	·	·	·	·												
65	2½		·	·	·	·	·	·											
80	3		·	·	·	·	·	·	·										
100	4									·	·	·							
125	-									·	·	·	·						
150	6									·	·	·	·	·					
200	8									·	·	·	·	·	·	·	·	·	
250	10									·	·	·	·	·	·	·	·	·	·
300	12									·	·	·	·	·	·	·	·	·	·
Nominal size	Versions with flow divider ST 2 · Areas highlighted in gray indicate versions of Type 3241 also available with pressure balancing																		
DN	NPS																		
25	1																		
32	-		·	·	·														
40	1½		·	·	·														
50	2		·	·	·	·													
65	2½		·	·	·	·	·												
80	3		·	·	·	·	·	·											
100	4									·	·	·							
125	-									·	·	·	·						
150	6									·	·	·	·	·					
200	8									·	·	·	·	·	·	·	·	·	
250	10									·	·	·	·	·	·	·	·	·	·
300	12									·	·	·	·	·	·	·	·	·	·
Nominal size	Versions with flow divider ST 3 · Areas highlighted in gray indicate versions of Type 3241 also available with pressure balancing																		
DN	NPS																		
25	1																		
32	-		·																
40	1½		·																
50	2		·																
65	2½		·	·	·	·													
80	3		·	·	·	·	·												
100	4									·									
125	-									·	·								
150	6									·	·	·							
200	8									·	·	·	·						
250	10									·	·	·	·	·	·	·	·	·	
300	12									·	·	·	·	·	·	·	·	·	·

Note:
Specifications do not apply to Type 3248

Note:
Specifications do not apply to Type 3248

Note:
Specifications do not apply to Type 3248

Table 2: Type 3248 Cryogenic Angle Valve · Direction of flow FTC**Table 2.1:** K_{VS} and C_V coefficients for Type 3248 · Equal percentage characteristic

Type 3248 · Equal percentage characteristic with direction of flow FTC															
K_{VS}		4	6.3	10	13	20	32	36	47	54	70	85	105	144	
C_V		5	7.5	12	15	23	37	42	55	62	80	100	121	170	
Seat Ø	mm	24		31	38	48	63	80	63	80	80	100	110	130	
Travel	mm	15							30						
	in	0.59							1.18						
Nominal size		Version without flow divider													
DN	NPS														
25	1	•	•												
32	–	•	•	•											
40	1½	•	•	•	•										
50	2	•	•	•	•	•									
65	2½		•	•	•	•	•								
80	3		•	•	•	•	•	•							
100	4								•	•	•	•			
125	–								•	•	•	•	•		
150	6								•	•	•	•		•	

Table 2.2: K_{VS} and C_V coefficients for Type 3248 · Linear characteristic

Type 3248 · Linear characteristic with direction of flow FTC															
K_{VS}		4	6.3	10	13	20	32	40	50	54	85	115	144	190	
C_V		5	7.5	12	15	23	37	47	60	62	100	135	170	220	
Seat Ø	mm	24		31		38	48	63	80	63	80	100	110	130	
Travel	mm	15							30						
	in	0.59							1.18						
Nominal size		Version without flow divider													
DN	NPS														
25	1	•	•												
32	–	•	•	•	•										
40	1½	•	•	•	•	•									
50	2	•	•	•	•	•	•								
65	2½		•	•	•	•	•	•							
80	3		•	•	•	•	•	•	•						
100	4									•	•	•			
125	–									•	•	•	•		
150	6									•	•	•		•	

Table 3: Type 3251 Globe Valve and Type 3256 Angle Valve · Direction of flow FTO

Table 3.1: K_{VS} and C_V coefficients for Type 3251 and Type 3256 (up to DN 300/NPS 12) · Equal percentage characteristic

Series 250 · Equal percentage characteristic with direction of flow FTO																				
K_{VS}	4	6.3	10	16	25	36	54	63	80	100	160	250	360	420	630	1000	1350	1650	2500	
C_V	5	7.5	12	20	30	42	62	75	95	120	190	290	420	485	735	1150	1560	1900	2900	
K_{V-1}	3.6	5.7	9	14.5	22	32	47	57	72	90	144	225	320	375	560	900	1200	1500	2250	
C_{V-1}	4.2	7	10.5	17	26	37	55	67	85	105	170	265	375	435	650	1040	1400	1730	2600	
K_{V-2}	3.2	5	8	13	20	29	43	50	63	80	125	200	290	340	500	800	1080	1320		
C_{V-2}	3.7	6	9.5	15	23	34	50	60	75	95	145	235	335	390	580	950	1250	1530	-	
K_{V-3}	3	4.8	7.5	12	20	27	40	47	60	75	120	190	270	315	480	750	1000	1250		
C_{V-3}	3.5	5.6	9	14	23	31	47	55	70	90	140	220	315	365	560	880	1150	1450	-	
Seat Ø	mm	24	31	38	50	63	80	100	125	150	200	250	300	350	400	500				
Travel	mm	15			30			60			120									
	in	0.59			1.18			2.36			4.72									
Nominal size DN NPS	Versions without flow divider · Areas highlighted in gray indicate versions also available with pressure balancing																			
25	1	·	·																	
40	1½	·	·	·	·															
50	2	·	·	·	·	·	·													
80	3	·	·	·	·	·	·	·	·	·										
100	4				·	·	·	·	·	·	·									
150	6						·	·	·	·	·	·								
200	8							·	·	·	·	·	·	·						
250	10							·	·	·	·	·	·	·	·					
300	12								·	·	·	·	·	·	·	·				
-	14										·	·	·	·	·	·	·			
400	16										·	·	·	·	·	·	·	·		
500	20											·	·	·	·	·	·	·	·	
Nominal size DN NPS	Versions with flow divider ST 1 · Areas highlighted in gray indicate versions also available with pressure balancing																			
25	1	·	·																	
40	1½	·	·	·	·															
50	2	·	·	·	·	·	·													
80	3	·	·	·	·	·	·	·	·	·										
100	4				·	·	·	·	·	·	·									
150	6						·	·	·	·	·	·								
200	8							·	·	·	·	·	·	·						
250	10							·	·	·	·	·	·	·	·					
300	12								·	·	·	·	·	·	·	·				
-	14										·	·	·	·	·	·	·	·		
400	16										·	·	·	·	·	·	·	·	·	
500	20											·	·	·	·	·	·	·	·	
Nominal size DN NPS	Versions with flow divider ST 2 · Areas highlighted in gray indicate versions also available with pressure balancing																			
25	1																			
40	1½																			
50	2	·	·	·	·	·	·													
80	3	·	·	·	·	·	·	·	·	· ¹⁾										
100	4				·	·	·	·	·	·	· ¹⁾									
150	6						·	·	·	·	·	· ¹⁾	· ¹⁾							
200	8							·	·	·	·	·	·	· ¹⁾	· ¹⁾					
250	10							·	·	·	·	·	·	·	·	· ¹⁾				
300	12								·	·	·	·	·	·	·	·	· ¹⁾			
-	14										·	·	·	·	·	·	·	·	·	
400	16										·	·	·	·	·	·	·	·	· ¹⁾	
500	20											·	·	·	·	·	·	·	·	
Nominal size DN NPS	Versions with flow divider ST 3 · Areas highlighted in gray indicate versions also available with pressure balancing																			
25	1																			
40	1½																			
50	2	·	·																	
80	3	·	·	·	·	·	·													
100	4				·	·	·													
150	6						·	·	·	·	·									
200	8							·	·	·	·	·								
250	10							·	·	·	·	·	·							
300	12								·	·	·	·	·	·						
-	14										·	·	·	·	·	·	·	·	·	
400	16										·	·	·	·	·	·	·	·	·	
500	20											·	·	·	·	·	·	·	·	

¹⁾ Pressure balancing only up to PN 160/Class 900

Table 4: Type 251GR Globe Valve and Type 251AR Angle Valve · Direction of flow FTO

Table 4.1: K_{Vs} and C_v coefficients for Type 251GR/251AR · Equal percentage characteristic

Series SMS with screwed-in seat · Equal percentage characteristic with direction of flow FTO														
K_{Vs}		4.3	6.2	7.8	13	21	32	42	74	90	140	210	320	580
C_v		5	7.2	9	15	24	37	49	85	105	162	243	370	670
K_{V-1}		3.9	5.6	6.9	12	19	29	38	66	82	126	190	290	520
C_{V-1}		4.5	6.5	8	14	22	34	44	76	95	146	220	335	600
Seat Ø	mm	24	27	27	33	42	55	55	70	85	110	130	170	228
Travel	mm	15	15	15	19	19	30	30	38	38	60	60	60	90
Nominal size	Version without flow divider													
NPS	DN													
½	15													
1	25	•	•	•										
1½	40	•	•	•	•	•								
2	50			•	•	•	•	•						
3	80					•	•	•	•	•				
4	100						•	•	•	•	•			
6	150									•	•	•	•	
8	200										•	•	•	•
Nominal size	Version with flow divider ST 1													
NPS	DN													
½	15													
1	25	•	•	•										
1½	40	•	•	•	•	•								
2	50			•	•	•	•	•						
3	80					•	•	•	•	•				
4	100						•	•	•	•	•			
6	150									•	•	•	•	
8	200										•	•	•	•

Table 4.2: K_{VS} and C_V coefficients for Type 251GR/251AR · Equal percentage characteristic

Series SMS with clamped-in seat · Equal percentage characteristic with direction of flow FTO																								
K_{VS}		4.3	6.2	6.9	7.8	13	19	21	32	38	42	74	82	90	126	140	210	290	320	520	580	700	1100	
C_V		5	7.2	8	9	15	22	24	37	44	49	85	95	105	146	162	243	335	370	600	670	810	1270	
Seat Ø	mm	24	27	27	27	33	42	42	55	55	55	70	85	85	110	110	130	170	170	228	228	280	330	
Travel	mm	15	15	15	15	19	19	19	30	30	30	38	38	38	60	60	60	60	60	90	90	120	120	
Nominal size		Version without flow divider																						
NPS	DN																							
½	15																							
1	25	•	•	•																				
1½	40	•	•		•	•	•																	
2	50				•	•		•	•	•														
3	80							•	•		•	•	•											
4	100								•		•	•		•	•									
6	150													•		•	•	•						
8	200															•	•		•	•				
10	250																		•		•	•		
12	300																				•	•	•	

Table 4.3: K_{Vs} and C_v coefficients for Type 251GR/251AR · Linear characteristic

Series SMS with screwed-in seat · Linear characteristic with direction of flow FTO														
K_{Vs}		4.3	6.9	9.4	13	19	26	47	74	100	152	273	363	630
C_v		5	8	11	15	22	30	54	85	116	177	315	420	730
K_{V-1}		3.9	6.2	8.5	12	17	23	42	66	90	137	245	327	570
C_{V-1}		4.5	7.2	10	14	20	27	49	76	105	159	284	378	660
Seat Ø	mm	24	27	27	33	33	42	55	70	85	110	130	170	228
Travel	mm	15	15	15	19	19	19	30	38	38	60	60	60	90
Nominal size	Version without flow divider													
NPS	DN													
½	15													
1	25	•	•	•										
1½	40	•	•	•	•	•	•							
2	50			•	•	•	•	•						
3	80						•	•	•	•				
4	100							•	•	•	•			
6	150									•	•	•	•	
8	200										•	•	•	•
Nominal size	Version with flow divider ST 1													
NPS	DN													
½	15													
1	25	•	•	•										
1½	40	•	•	•	•	•	•							
2	50			•	•	•	•	•						
3	80						•	•	•	•				
4	100							•	•	•	•			
6	150									•	•	•	•	
8	200										•	•	•	•

Table 4.4: K_{VS} and C_V coefficients for Type 251GR/251AR · Linear characteristic

Series SMS with clamped-in seat · Linear characteristic with direction of flow FTO																							
K_{VS}		4.3	6.9	8.5	9.4	13	19	23	26	42	47	74	90	100	137	152	273	327	363	570	630	990	1400
C_V		5	8	10	11	15	22	27	30	49	54	85	105	116	159	177	315	378	420	660	730	1145	1620
Seat Ø	mm	24	27	27	27	33	33	42	42	55	55	70	85	85	110	110	130	170	170	228	228	280	330
Travel	mm	15	15	15	15	19	19	19	19	30	30	38	38	38	60	60	60	60	60	90	90	120	120
Nominal size		Version without flow divider																					
NPS	DN																						
½	15																						
1	25	•	•	•																			
1½	40	•	•		•	•	•	•															
2	50				•	•	•		•	•													
3	80								•		•	•	•										
4	100										•	•		•	•								
6	150													•		•	•	•					
8	200															•	•		•	•			
10	250																		•		•	•	
12	300																				•	•	•

Table 5: Type 3254 Globe Valve · Direction of flow FTO

Table 5.1: K_{VS} and C_V coefficients for Type 3254 · Equal percentage characteristic

Series 250 · Equal percentage characteristic with direction of flow FTO													
K_{VS}	54	63	80	100	160	250	360	420	630	1000	1350	1650	2500
C_V	62	75	95	120	190	290	420	485	735	1150	1560	1900	2900
K_{V-1}	47	57	72	90	144	225	320	375	560	900	1200	1500	2250
C_{V-1}	55	67	85	105	170	265	375	435	650	1040	1400	1730	2600
K_{V-2}	43	50	63	80	125	200	290	340	500	800	1080	1320	-
C_{V-2}	50	60	75	95	145	235	335	390	580	950	1250	1530	
K_{V-3}	40	47	60	75	120	190	270	315	480	750	1000	1250	-
C_{V-3}	47	55	70	90	140	220	315	365	560	880	1150	1450	
Seat Ø mm	63	80	100	125	150	200	250	300	350	400	500		
Travel	mm	30				60				120			
	in	1.18				2.36				4.72			
Nominal size DN NPS	Versions without flow divider · Areas highlighted in gray indicate versions also available with pressure balancing												
80 3	•	•	•										
100 4	•	•	•	•									
150 6	•	•	•	•	•	•							
200 8		•	•	•	•	•	•	•	•				
250 10		•	•	•	•	•	•	•	•	•			
300 12				•	•	•	•	•	•	•	•		
400 16						•	•	•	•	•	•	•	•
500 20									•	•	•	•	•
Nominal size DN NPS	Versions with flow divider ST 1 · Areas highlighted in gray indicate versions also available with pressure balancing												
80 3	•	•	•										
100 4	•	•	•	•									
150 6	•	•	•	•	•	•							
200 8		•	•	•	•	•	•	•	•				
250 10		•	•	•	•	•	•	•	•	•			
300 12				•	•	•	•	•	•	•	•		
400 16						•	•	•	•	•	•	•	•
500 20									•	•	•	•	•
Nominal size DN NPS	Versions with flow divider ST 2 · Areas highlighted in gray indicate versions also available with pressure balancing												
80 3	•	• ¹⁾	• ¹⁾										
100 4	•	•	•	• ¹⁾									
150 6	•	•	•	•	•	• ¹⁾							
200 8		•	•	•	•	•	• ¹⁾	• ¹⁾					
250 10		•	•	•	•	•	•	•	• ¹⁾				
300 12				•	•	•	•	•	•	• ¹⁾			
400 16						•	•	•	•	•	•	• ¹⁾	
500 20									•	•	•	•	•
Nominal size DN NPS	Versions with flow divider ST 3 · Areas highlighted in gray indicate versions also available with pressure balancing												
80 3													
100 4	•												
150 6	•	•	•	•	•								
200 8		•	•	•	•	•	•						
250 10		•	•	•	•	•	•	•	•				
300 12				•	•	•	•	•	•	•			
400 16						•	•	•	•	•	•		
500 20									•	•	•	•	•

Table 5.2: K_{VS} and C_V coefficients for Type 3254 · Linear characteristic

Series 250 · Linear characteristic with direction of flow FTO												
K_{VS}	63	100	130	250	320	500	900	1300	1700	2100	3200	
C_V	75	120	150	290	375	580	1040	1500	2000	2450	3700	
K_{V-1}	57	90	115	225	280	450	800	1150	1530	1900	2900	
C_{V-1}	67	105	135	265	325	520	950	1350	1800	2200	3300	
K_{V-2}	50	80	105	200	255	400	720	1030	1350	1680	-	
C_{V-2}	60	95	120	235	295	465	835	1200	1560	1940		
K_{V-3}	47	75	100	190	230	375	675	950	1275	1600	-	
C_{V-3}	55	90	120	220	270	435	780	1100	1475	1860		
Seat Ø	mm	63	80	100	125	150	200	250	300	350	400	500
Travel	mm	30			60			120				
	in	1.18			2.36			4.72				
Nominal size DN NPS	Versions without flow divider · Areas highlighted in gray indicate versions also available with pressure balancing											
80 3	·	· ¹⁾										
100 4	·	·	·									
150 6	·	·	·	·	·							
200 8		·	·	·	·	·						
250 10		·	·	·	·	·	·					
300 12			·	·	·	·	·	·				
400 16					·	·	·	·	·	·	·	
500 20							·	·	·	·	·	
¹⁾ Reduced K_{VS}/C_V coefficients with Class 900 to 2500: $K_{VS} = 90$; $C_V = 105$												
Nominal size DN NPS	Versions with flow divider ST 1 · Areas highlighted in gray indicate versions also available with pressure balancing											
80 3	·	·										
100 4	·	·	·									
150 6	·	·	·	·	·							
200 8		·	·	·	·	·						
250 10		·	·	·	·	·	·					
300 12			·	·	·	·	·	·				
400 16					·	·	·	·	·	·	·	
500 20							·	·	·	·	·	
Nominal size DN NPS	Versions with flow divider ST 2 · Areas highlighted in gray indicate versions also available with pressure balancing											
80 3	·	· ¹⁾										
100 4	·	·	· ¹⁾									
150 6	·	·	·	·	· ¹⁾							
200 8		·	·	·	·	· ¹⁾						
250 10		·	·	·	·	·	· ¹⁾					
300 12			·	·	·	·	·	· ¹⁾				
400 16					·	·	·	·	·	·	· ¹⁾	
500 20							·	·	·	·	·	
Nominal size DN NPS	Versions with flow divider ST 3 · Areas highlighted in gray indicate versions also available with pressure balancing											
80 3												
100 4	·											
150 6	·	·	·	·								
200 8		·	·	·	·							
250 10		·	·	·	·	·						
300 12			·	·	·	·	·					
400 16					·	·	·	·	·	·		
500 20							·	·	·	·	·	

Table 6: Type 3256 Angle Valve · Direction of flow FTC

Table 6.1: K_{VS} and C_V coefficients for Type 3256 · Equal percentage characteristic

Type 3256 · Equal percentage characteristic with direction of flow FTC																	
K_{VS}		4	6.3	10	13	20	30	47	54	70	85	144	220	320	400	600	950
C_V		5	7.5	12	15	23	35	55	62	80	100	170	255	375	465	700	1100
Seat Ø	mm	24		31	38	50		63	80		100	125	150	200		250	300
Travel	mm	15					30					60				120	
	in	0.59					1.18					2.36				4.72	
Nominal size		Version without flow divider · Pressure balancing on request															
DN	NPS																
25	1	•	•														
40	1½	•	•	•	•												
50	2	•	•	•	•	•	•										
80	3	•	•	•	•	•	•	•	•	•							
100	4				•	•	•	•	•	•	•						
150	6							•	•	•	•	•	•				
200	8								•	•	•	•	•	•	•		
250	10								•	•	•	•	•	•	•	•	
300	12										•	•	•	•	•	•	•

Table 6.2: K_{VS} and C_V coefficients for Type 3256 · Linear characteristic

Type 3256 · Linear characteristic with direction of flow FTC																	
K_{VS}		4	6.3	10	13	20	35	54	85	115	220	280	480	860	1240		
C_V		5	7.5	12	15	23	40	62	100	135	255	325	560	1000	1440		
Seat Ø	mm	24		31		38	50	63	80	100	125	150	200	250	300		
Travel	mm	15					30					60				120	
	in	0.59					1.18					2.36				4.72	
Nominal size		Version without flow divider · Pressure balancing on request															
DN	NPS																
25	1	•	•														
40	1½	•	•	•	•	• ¹⁾											
50	2	•	•	•	•	•	• ¹⁾										
80	3	•	•	•	•	•	•	•	• ¹⁾								
100	4				•	•	•	•	•	•							
150	6							•	•	•	•	•					
200	8								•	•	•	•	•	•			
250	10								•	•	•	•	•	•	•		
300	12										•	•	•	•	•	•	•

¹⁾ Reduced K_{VS}/C_V coefficients with Class 900 to 2500 on request

Ordering text

The following specifications are required on ordering:

Perforated plug for valve	Type ...
Body material	According to associated data sheet
Type of end connections	According to associated data sheet
Nominal size	DN .../NPS ...
Pressure rating	PN .../Class ...
Flow coefficients	K_{VS} .../ C_v ...
Direction of flow	FTO: Flow-to-open (flow under the plug) FTC: Flow-to-close (flow over the plug)

For a retrofit, the details below are additionally required

Seat diameter mm
Travel mm

